



tarkan

Cantar's mirror, **v1.14** p.51

firmware v 2.31

• ultra precise auto-slate p.23

• any input to t7, monomix to t8 p.28

• save and reload all settings p.33

• 'wild' 'all' and 'trio' pdf-reports p.38

• editor friendly poly-rotate p.39

• stereo monitoring soundfield-b p.44

• playback, adr, remix **rec&play** p.48

tarkan p.51

cantarem p.53

arcana-w p.54

majax p.56



Aaton Cantar-X1 &2

Keep in Touch

Manuals & software	p.3
Cantar User's List, Photo Gallery	p.3
The PostChain	p.3
Software versions	p.3
Cantar-X1 to X2	p.3

Description

Permanently accessible faders	p.4
Bottom connections	p.5
Swiveling front panel buttons	p.6
In-Grids and Out-Maps	p.7
Pan-pots	p.7
Circular modulometers for T1-T6	p.8
Rectangular screen	p.8
Triple crown	p.9

Operating positions

MainSelector 'West'	p.10
MainSelector buttons	p.10

STOP

Power

Starting and stopping	p.11
Twin battery safety	p.11
Minimum/Maximum voltage	p.11
Battery check	p.11
Power Consumption	p.11
Lithium-Ion batteries	p.11
Flight restriction rules	p.11

STOP

Files

Error-free filing system	p.12
Project creation	p.12
Workday	p.12
Filename	p.12
Operational Problem	p.12

STOP

Time & clocks

Calendar Time & Sync Time	p.13
Internal Free-Run master-clock	p.13
Do not power down the master	p.14
Internal Record-Run clock	p.14
Internal clock & clapstick	p.14
Slaved to an external clock	p.14
Sampling Rate vs. Audio-TC	p.15
On planet Earth	p.15
On the 'Slow-planet'	p.15
A for Avid v11	p.15
B for Barebone	p.15
C for Compensated (Fake)	p.15

TEST

Mic Phantom power	p.16
Limiters, Inversion	p.16
Filters and attenuators	p.16
Differential delays	p.16
Mic & Line linking	p.17
Stereo pairs & Surround	p.17
Tuning the balances	p.17
Mixer panpots and faders	p.17
Mixer miXa miXb outputs	p.17
M/S monitoring	p.18
Track disarming	p.18
Headphone level	p.18
Line-out/Foldback level	p.18
Check In-Grids & Out-Maps	p.18
Rec&Play rehearsal	p.18

PPR

Pre-Post-Record

Pre-recording buffer	p.19
Sc&Take, Track-names, TapeRef	p.19
Post-recording metadata editing	p.20
File splitting	p.20
Last take erasure	p.20
False start (trash a file)	p.20
Remote Roll by LTC	p.21
Remote control PDA/keyboard	p.21

REC

Record

Modulometers	p.22
Solos of the inputs and tracks	p.22
Locking the faders	p.22
Reference Tone generator	p.22
Talkback mic	p.22
Warning beeps	p.22
Take-type	p.22
Record tally	p.23
AutoSlate	p.23
Markers	p.23
Record & Play	p.23

PLAY

Commands	p.24
LTC for VTR chase	p.24
Play-card creation	p.24

BROWSE

File handling

Find a file	p.25
Edit Metadata	p.25
Trash/Revive a file	p.25
Index a Play-file	p.25
Wake up HDD!	p.25

Operand positions

MainSelector 'East'	p.26
Rectangular screen rows	p.26

ROUTINGS

Create In-Grids	p.27
AES sample rate converters	p.28
16-Track by Word-clock	p.28
Rec&Play In-Grids	p.28
Create Out-Map banks	p.29
Digi1 to Digi8 outputs	p.30

AUDIO/TC

Audio parameters	p.31
Timecode parameters	p.32

TECHSET

Save and transfer Setups	p.33
Software install	p.35

SESSION

Project selection/creation	p.36
HDD formatting	p.36
DVD-RAM formatting, Scan disk	p.37
Sound-Reports: CSV, ALE, PDF	p.37

BACKUP

IdleCopy, Backup@Call, PolyStore	p.39
File treatments	p.40
File rescuing	p.41

Tutorials

Backup & Report	p.42
Drives and Media	p.43
Surround, Onboard mixer	p.44
Camera sync	p.46
REC with simultaneous PLAY 	p.48

Companions

Tarkan	p.51
CantaRem	p.53
Arcan-w	p.54
OriginC, GMT	p.55
Majax, IndawPass	p.56
PostChain, Titan-3	p.56

Annex

Connectors & Accessories	p.57
Quick guide sheets	p.58

User manual

The latest User Manual is on: <http://www.aaton.com/products/sound/cantar/usermanual.php> ; to read it on iPhones, use FileMagnet: <http://magnetismstudios.com/FileMagnet>
Note: iPhone v2.2.1 supports all PDF's.

Software

Cantar, Arcan, Tarkan, Majax software can be downloaded from: <http://www.soft.aaton.com/swcantar/>

- **first visit:** click 'create an account', enter your details, don't forget the country. After a few seconds, you will receive an email with your password. Enter this password with your email address in the login page.
- **next visits:** forgotten password? Click 'lost password',

From Cantar-X1 to X2

All Cantar-X1s can be upgraded to X2s.

- Motherboard (CM-5) carries a more powerful FPGA (*Field Programmable Gate Array*).
- A-to-D converters (AD-5) provide nine audio delays (up to 85ms @ 48kHz).

New Features

– X1 & X2 + X2 only

- v2.31** Nov. 2009 – Track names appear in the ALE under the T1 to T8 column headers for easy Avid MC extraction.
- v2.30** Sept. 2009 – Mute for Line-out and/or Foldback in PLAY.
– Stored setups go from ten to twenty. – Take-type resets to 't' after the scene increments. – MS jog pan direction identical to others. – 250MB auto jump keeps eight track polys under 2GB.
– Bug fixes: no more wrong play-LTC after pause; Cantarem can't accidentally disarm T7T8. + Operands are accessible from Tarkan v1.13. + Tarkan's 'Virtual Cantarem' has access to all Cantar gain controls.
- v2.28** Aug. 2009 – Absolute-TC permanently displayed [shift eye] in PLAY; back to elapsed TC upon exit. – Cantarem can mix T1-T7 into Xb (T8), or T1-T8 to Foldback, Line-out and Phones. – The ALE incremental 'Index' is replaced by 'SqScTk', and the first autoslate TC is stored in the Mark In column. – Fudge in 'AUDIO/TC.14' adds 60ms to the file's TC. – No freeze when playing 'Majax cantarized' foreign files. – BattAlert range extended to 15V. – Improved SATA disk management.
- v2.26** Feb. 2009 – Idle backup can be interrupted while saving T7T8 after a T1-T8 polyrotate. – Mic3 master of Mic4 & Mic5.
– Direct PLAY of the take preceding a deleted one. – Fat-32 for

it will be sent to your email address.

Cantar software is accessible to registered owners only; beta versions are not to be used for commercial assignments.

Cantar Users' Group

Exchange tips with other cantarists:

<http://ulyse.aaton.com/cgi-bin/mailman/listinfo/cantar-users>

Pictures on the road

Send us your 'Cantar at work' pictures, we will put the best ones on the gallery: <http://www.aaton.com/gallery/>

Post Production helper

Spread the 'CantarPostChain-26' tutorial around:

<http://www.aaton.com/documentation/>

- Interface board (ET-1) brings 100BaseT Ethernet through an RJ45 socket. Same software but some functions require X2's power: Rec&Play; Ethernet; Differential analog delays; AutoSlate on line-inputs and tracks; Wordclock sync.

– matting of CF cards. – SoundReport generated once backup@call is completed. + Tarkan v1.11 adds CSV to the PDF SoundReport.
+ Tarkan completion menu fits WinXP netbook screens.

v2.24 Nov. 2008 – Windows PCs handle 'unmounted' internal drive. – Simultaneous recording on a mix of internal - external, P/ATA - S/ATA drives. – Line-in links for Soundfield ST350. – PolyRotate by one or two ranks. – T8T8 backup. – False-start: take-type 'n' keeps the take # for the next. – Trash a file/Revive files in BROWSE. – Swift access to ROUTINGS with no PLAY/BROWSE triggering. – Thumb-free check/select In-Grids and Out-Maps. – All letters available for seq./scene. – Delayed IdleCopy activation. – DVD-RAM exact backup space is displayed. – Erratic behaviour following PDF creation, fixed. + Linking-Trios in the CSV SoundReport. + Tarkan v1.09 brings pan-pot control, T7T8 settings, metadata editing and PDF generation.

v2.15 March 2008 – In-Grids to T7T8 displayed with T1-T6 banks. – Mixdown (+T7) to T8. – Line-out/Foldback gain from TEST. – 'So' monitoring of the mix in TEST, REC and PLAY: Xa (center), Xb (center), Xa Xb (center), Xa Xb (left/right). – One hand Solo/Filter adjust. – 3sec. delay protection of limiters. – Storage of project's sound-report headers with 'save setup'. – Clockwise jog for time and operands.

Permanently accessible faders

The Cantar interface is the easiest to use under the most technically demanding conditions:

- It offers the largest display surface of all portable recorders, which simultaneously shows every critical recording parameter.
- The custom designed high contrast displays remain viewable under bright light (sun, sand, sea, snow, storm), and at very low temperatures too.
- The swiveling front panel always provides the best viewing angle for both on cart and over the shoulder work.
- The large twelve position

MainSelector eliminates diving into sub-menus.

- The three-crown turret gives instant access to all recording and monitoring configurations while wearing heavy winter gloves.
- Nine rotary faders (analog inputs) plus six linear faders (mixdown) devoted to one specific task are faster to handle than multi-function knobs.
- An important consideration for desert or high seas work: all of the mechanical actuators (faders, sliders, buttons, selectors) are sandproof and waterproof.

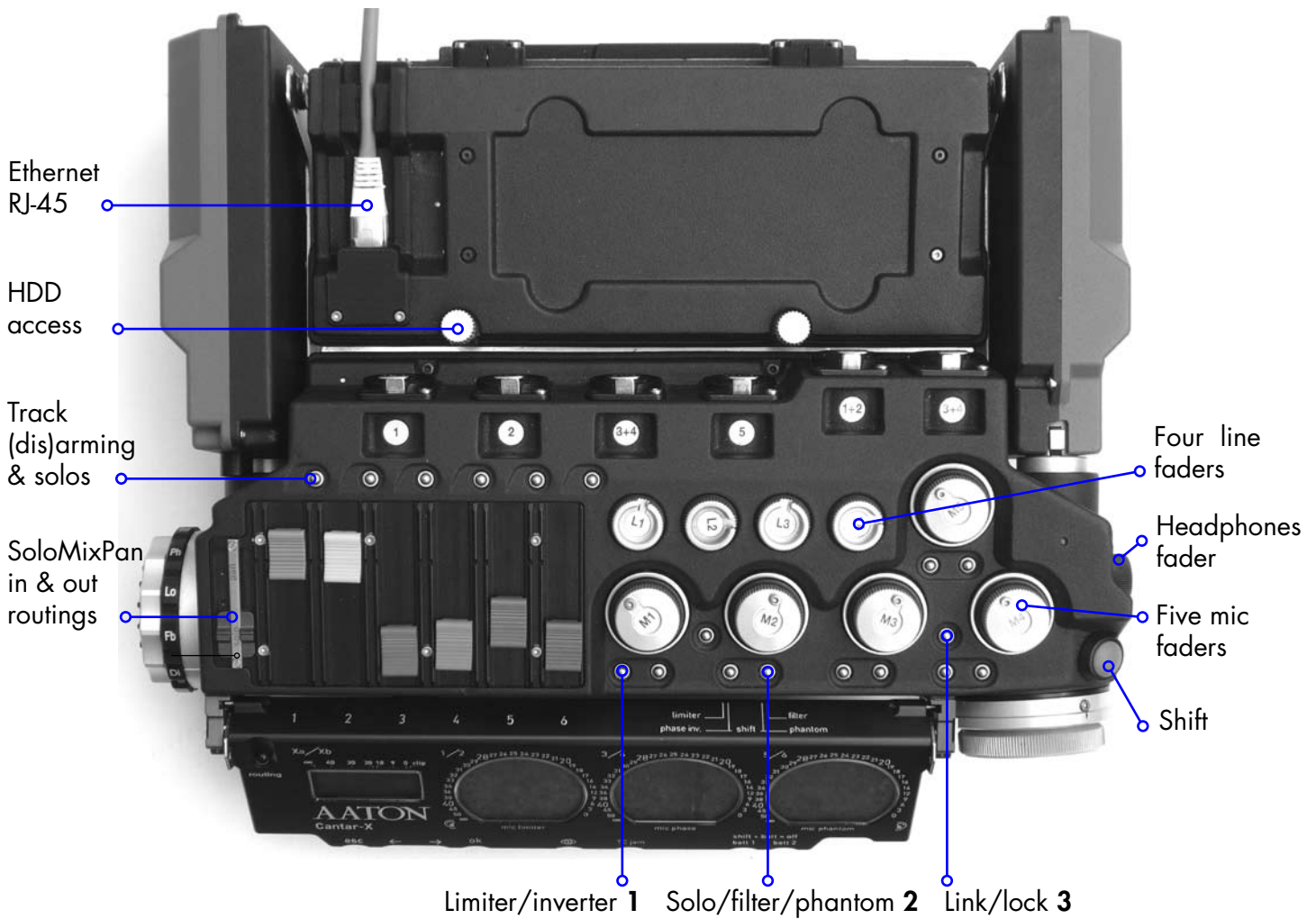

- | | |
|---|---|
| <p>1 [lim-inv] Analog limiter ON/OFF.
 [shift] [lim-inv] Input signal inversion.</p> <p>2 [so-fil-tom] Solo & Filter. Balance access.
 [shift] [so-fil-tom] Phantom 48V ON/OFF.</p> <p>3 [link-lock] Leftside (un)locks Mixer faders
 Rightside (un)locks mic/line faders.
 [shift] [link-lock] Links mics.</p> | <p>[SoloMixPan] pushed to the bAttery side:
 [routing] displays the inputs to <i>trAcks</i>.
 [track-solo] (end of fader button) shows <i>pAn-pots</i>.</p> <p>[SoloMixPan] pulled to the Operator side:
 [routing] displays the outputs to <i>mOnitors</i>.
 [track-solo] (end of fader button) activates track <i>sOLO</i>.</p> |
|---|---|

Protected ins & outs

To complement the waterproof design, all audio sockets are pointed toward Earth, the same direction that rain falls. This concept has the notable side effect that no plugs protrude from the sides; this allows third party designers to build very narrow 'Made for Cantar' carts!

- The **SubD 15** (p.57) is used to connect CantarRem (p.53) or a USB-PS2 keyboard adapter .
- The **SubD 25** (p.57) is the AES in/out connector which can loop playback signals when in "REC&PLAY" mode.
- The **3/8" screw** is placed at the center of gravity

between three rubber pads, and is used to secure the Cantar onto a cart.

- The **weep hole**, underneath the phone-jack socket, is a drainage port for water that has entered through the phone-jack.
- To **extract** the internal DVD/DVD-RAM burner, first remove its lateral retaining screw (Aaton ref. 20 110 45), then introduce a pencil or tooth pick into the DVD extractor hole to push the drive out of the Cantar housing (see the DVD burner extraction arrows on the picture below).

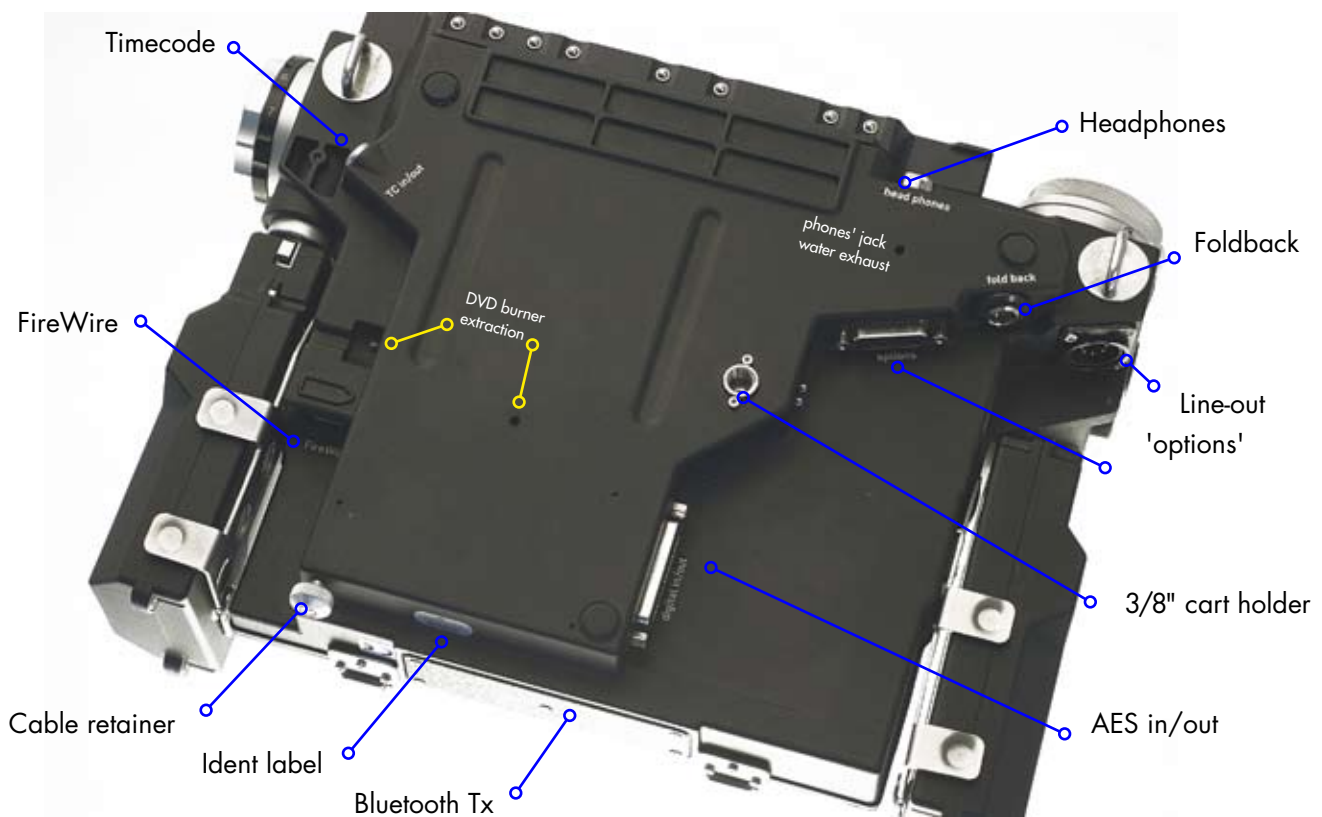

Rules about **FireWire** cables

- The **cable retainer screw** should be used at all times (use gaff-tape if your Cantar is not equipped with it) to avoid intermittent contact or sudden cable pull-out. An intermittent FireWire connection can induce 'bus hangs' and can even stop recording on both the external and internal disks.
- **DO NOT plug a cable into the Cantar FireWire socket while it is powered.** The FireWire6 socket that powers external disks and burners has a HOT 12V pin in it;

If the plug enters at an angle, it will produce a short between the +12V pin and the in/out pins and DESTROY the Cantar FireWire driver. Please follow the HDD formatting instructions (p.36).

- For 15" MacBookPro with 800 FireWire socket only, use an 800 to 400 cable, google ie9496-3.
- Only use **ferrite choke ring equipped** high quality FireWire cables, not the cheap skinny ones.

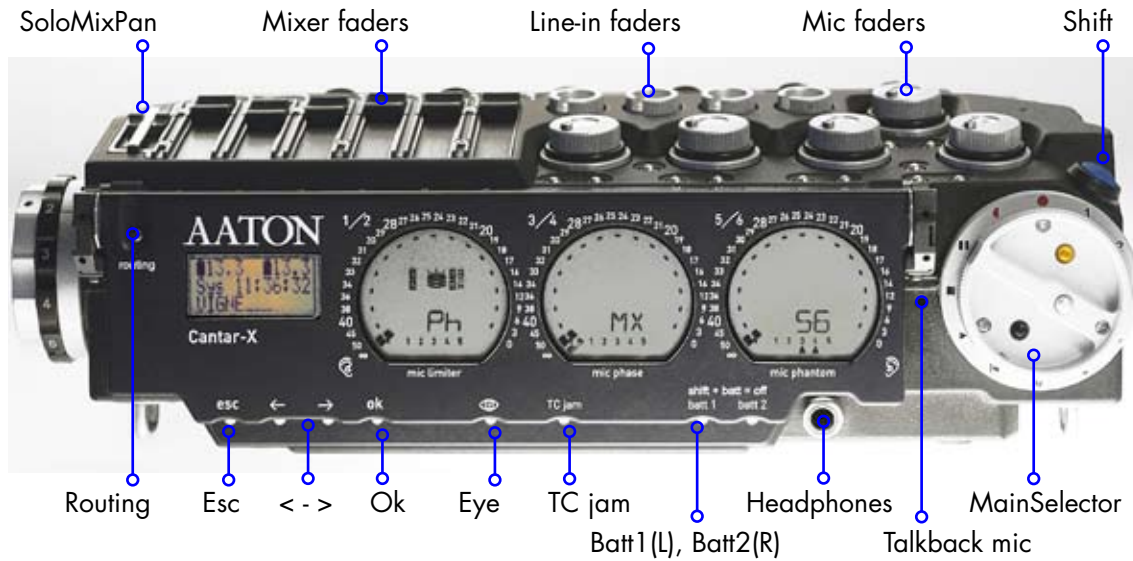

Front panel buttons

- [routing] [SoloMixPan] battery side: In-Grids.
- [routing] [Solo/MixPan] operator side: Out-Maps.

- [esc] pause/restart from there.
- [shift] [esc] in PLAY, *continuous play of files toggle.*
in PPR, *'comment' line erasure.*

- [<] [>] prev/next play-card (p/n file if no card)
in 'Operands', other parameter value.
- [shift] [<] [>] prev/next play-file.

- [ok] start/stop playback; in 'Operands' push
focus to bottom row; value validation.
- [shift] [ok] digitization parameters and TC fps view.

- [eye] in 'Operatings', toggles T5T6 / T7T8
on right screen; in 'Operands', 'Help'.
- [shift] [eye] toggles rectangular screen bottom row
between 'filetag&duration' and 'scene&take'
(preference stored until Cantar is turned 'OFF').

- [TC jam] in PLAY, shows absolute TC; in TEST,
a 3 sec. press sets Sync clock to incoming LTC.
- [shift] [TC jam] in TEST, stops 'int c' reminder blinking.

- [batt L] or [R] short pressure: battery voltage;
long pressure: battery on duty.
- [shift] [batt] in STOP, turns 'OFF' Cantar.

Headphones

1/4" jack in an isolated compartment. The headphone amplifier is powerful enough to drive loudspeakers down to 8 ohms. The stored output level of the headphones is protected by the [shift] button.

Talkback mic

Nested near the MainSelector, the automatic gain talkback mic can be routed to line-out, foldback and tracks (p.10).

Circular and Rectangular screens

Always visible under the brightest light (p.7 & p.8).

TripleCrown and MainSelector

Easy to manipulate even with winter gloves on, they give access to all operating actions and operands (p.9, p.10 & p.26).

Mixer's faders

Dustproof and waterproof, they are magnetically driven. The black fader caps can be easily replaced with colored ones.

DVD burner

The burner is protected by the swiveling front panel, to replace it see p.5, p.43 & p.57. The currently installed Matsushita UJ-85J DVD-RAM /±R burner is a slot machine.

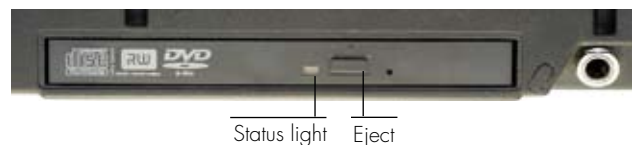

Circular screens

These are the largest, easiest-to-read screens found on any audio recorder. They provide the user with ongoing data concerning every aspect of the machine's operation.

It takes a few hours getting used to them since five display paradigms are used for the many functions they handle. Once you are familiar with these functions, you will be driving the fastest machine you have ever driven.

- 1** input grids. The six iso tracks graphically display their links at the push of a button, even while recording.
- 2** output maps. Thanks to the three screen layout emulating the left, both and right 'ears', the monitor maps are immediately understood.
- 3** progressive pan-pots. The contribution of each track to the mixdown has never been so clear.
- 4** circular modulometers. Their round shape makes the signal level easy to appreciate in a wink.
- 5** monitoring physical status. Permanent control of the disks, tracks, and setups.

1 Input grids

The available 'Inputs' are shown in each circular screen: line 1 to line 4, mic 1 to mic 5, digi 1 to digi 6. The six tracks to which they can be connected are grouped in pairs, e.g. T1T2, T3T4, T5T6 on the three screens.

The method to create routing-configurations by linking inputs and tracks is explained in the section *Routings* (p.27).



With the [SoloMixPan] slider pushed toward the battery, the [routing] button (top-left of the swiveling panel) instantly displays the 'inputs to tracks' grid, even while recording.

(In the picture above, the middle screen displays 'A4', the routing in use).

Fifteen preset routing grids are stored in three banks. Each bank holds five grids to help you sort and memorize your configurations (e.g. A1 to A5 for mic only setups, B1 to B5 when some line-inputs are on duty, C1 to C5 for complex setups that include digi-ins). The [config] crown gives instant sequential access to all of them.



2 Output maps

Here is where Cantar's three screen 'mapping' is at its best. Audio signals going to the left ear show on the left screen, signals to be listened to in mono show on the middle screen and those going to the right ear are on the right screen.

All inputs, recorded or not (very useful in Rec&Play), and all tracks can be monitored along different configurations for each of the eight independent output channels: **Ph** Phones, **Lo** Line-out, **Fb** Foldback and **Do** Digital-out. 26 different 'output routing' maps are available; the black [monitor] crown gives instant access to all of them (p.29).



In the example above, the 'Ph d' phone routing indicates: track 5 goes to the left ear, track 1 and track 2 go to the center (both ears) and track 6 goes to the right ear. With the [SoloMixPan] slider pulled toward the operator side, pressure on the [routing] button instantly displays the current monitor configuration.

note: the [routing] button is required to change from one grid to another, it is a protection against wild and lethal changes, but it is not required to change from one map to another in the course of a recording.

3 Pan-pots to the mixdown

Push the [SoloMixPan] slider toward the battery side, press the [track-solo] button next to the mixer linear fader: the pan-pot of this track goes under [jog] control and indicates its left/right contribution to either channel of the mixdown.



T1 & T2 left T3 center, T4 left T5 left, T6 right

The spatial position of all pan-pots is visible on the circular screens while the dBFS value of the selected pan-pot is displayed in the rectangular screen (see next page).

4 Circular modulometers

Cantar's large circular modulometers, visible under the brightest light as well as in the dark, are the most accurate metering tools found in any portable recorder. They feature a non-linear scale with increased resolution (1dB) in the most important range: -55 to -40dBFS (5dB per segment); -40 to -32dBFS (2dB / segment); -32 to -12dBFS (1dB / segment); -12 to 0dBFS (3dB / segment).

The peak level segment hold duration is adjustable from one-half to five seconds (see TECHSET.13).

The tracks are grouped into 'natural' pairs: T1T2, T3T4, T5T6. When a track is momentarily dis-armed, its modulometer appears dashed.



5 Monitoring physical status

The center of each circular screen continually displays the status of the main recording elements:

- activity of the internal HDD ('three-platter' icon on the left screen), the external HDD ('three-platter' icon on the middle screen), and the DVD ('one-platter' icon on the right screen). Disk activity is highlighted by the presence of the track IDs recorded on it.



left screen
Internal HDD

middle screen
External HDD

right screen
CD/DVD

- sync clock mode: either master **int c** or slave **ext c**.
- mic preamplifier status: Limiter On/Off, Direct/Invert, Phantom On/Off.
- the current monitor map name (sent to the phones too) is constantly displayed by large alphanumeric characters.
- the activation of the *mixdown recording* on T7T8 is indicated by the 'mix' icon next to the '7' and '8' black squares.

note: the screens are visible in very bright sunlight; to save backlight power, see TECHSET.05 'Backlight' (p.33).



Rectangular screen

- Operating positions (p.10)

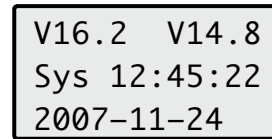

In **STOP**

top row: batt-L & batt-R voltage
middle row: system time
bottom row: system date.



In **TEST** or **REC**

top row: T7T8 modulometers in dBFS: -50 -45 -40 -38 -36 -34 -32 -30 -28 -26 -24 -22 -20 -18 -16 -14 -12 -9 -6 -3 0 Clip.

To display T7T8 levels with higher precision, press the [eye] button, this will swap T7T8 with T5T6 on the right circular screen.

The [jog] overwrites the T7T8 bargraphs with battery voltage, available disk space, or remaining recording time calculated from the current track count, bit-depth and sample rate.

middle row: the source and the TC stamped in the audio files: 'Atc' (ASCII-TC), 'Ltc' (jam from LTC), 'Stc' (from the system calendar), 'Otc' (operator entered TC), 'Rtc' (Record-Run TC), and 'Etc' (slaved to an external clock).

bottom row: (in TEST) current project name; (in REC) 'filetag & duration' or 'scene & take' by [shift] [eye]. While adjusting a pan-pot, the track rank, plus the maximum gain value of the whole mixer panel (0dB or +6dB) are displayed.

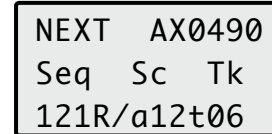

In **PPR** or **BROWSE**

scene, take, track-names, comments, Sound-Roll/Shoot Day, for their editing (p.19 & p.25).

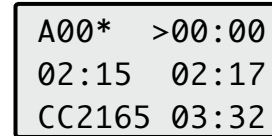

In **PLAY**

player's position, cue points, absolute time, 'filetag & duration' or 'scene & take' (p.24).

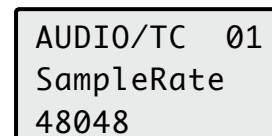

- Operand positions (p.26)

In **AUDIO/TC**, **TECHSET**, **SESSION** and **BACKUP**

the pathtree of each parameter:

top row: the 'Operand', e.g. AUDIO/TC. *middle row:* parameter name, e.g. Sample-Rate. *bottom row:* parameter value, e.g. 48048.

In TEST, PPR and REC, depending on the [SoloMixPan] slider position, the [routing] button displays the input routing templates called *In-Grids* or the active output routings called *Out-Maps*.

The large all weather triple crown is used to check and select the routings with only one hand.

note: to create routings, see p.27 to p.30.

Monitor Crown

1 So mic, line, digi-ins, active tracks and combinations of the mixer outputs directly sent to the headphones as 'solos'.

2 Ph seventeen user configurable maps (A to Q) plus the stereo mixer output to headphones.

3 Lo nine user configurable maps (R–Z) plus the stereo mixer output to dual line-out (XLR 5).

4 Fb nine user configurable maps (R to Z) plus the stereo mixer output to dual foldback out (mini XLR 3).

5 Do nine user configurable maps (R to Z) plus the stereo mixer output to digi-out on AES7&8.

The headphones also receive the signal sent to the output being selected/configured.

Config Crown

In-Grids

To check and select the *In-Grids*, **PUSH** the [SoloMixPan] slider to the battery side and press or click-in/click-out the [routing] button. The silver [config] crown gives sequential access to fifteen *In-Grids*, the last in use is displayed first.

Out-Maps

To check the *Out-Maps* for each **Ph**, **Lo**, **Fb** and **Do** outputs, **PULL** the [SoloMixPan] slider to the operator's side, and press or click-in/click out the [routing] button with the thumb and rotate the black [monitor] crown.

To browse the *Out-Maps* and select another one, rotate the silver [config] crown, the active map will be the one displayed when closing the [routing] command.

note: selecting a different *Out-Map* while recording doesn't affect the recorded signal.



Jog Crown

The [jog] is used: to move the cursor in the routing circular screens; to edit scene, take and comments; to select high pass filters; to adjust the backlight's intensity; to control the pan-pots; and to scrub the player in fast forward/reverse. Both the [jog] and [config] crowns increment time and operand values while rotating **clockwise**.

note1: [shift] [jog] accelerates the speed 10x.

note2: the Operand's middle and bottom rows of the rectangular screen can be browsed by the [>] [<] arrows just as easily as with the [jog].

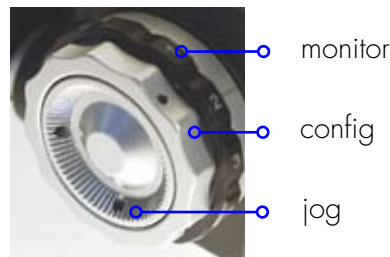



MainSelector positions

The [MainSelector] is easy to manipulate even while wearing heavy winter gloves; it gives direct access to all essential functions.

The OPERATING (West) positions control the recording, annotation and playback of audio files. **To get access to the Rec&Play positions, press and hold the blue [shift] button while rotating the [MainSelector]** (p.48 & p.49).

The OPERAND (East) positions, which establish Cantar's operating parameters, are described on p.26.

Standard positions

REC
PPR
TEST
STOP
PLAY
BROWSE

Rec&Play positions

● BLUE-REC
(BLUE-PPR
|| BLUE-TEST
■
> BLUE-PLAY
< BLUE-BRWS

MainSelector buttons

[black], [silver] and [gold] buttons can be activated by the thumb, while the blue [shift] button may be pressed by the index-finger.

- [silver] in REC, insert a marker on-the-fly.
in TEST, after [routing] opens routing creation (coming soon)
in PLAY, go to operator's record-markers.
- [shift] [silver] in REC, trigger AutoSlate detection.
in PPR, toggle take editor (PREV/NEXT take).
in TEST, open LEVEL&DELAY menu.
in PLAY go to AutoSlate marker.
- [black] in REC, PPR, TEST, talkback mic activation.
in PLAY, inserts a play mark.
in BLUE-PLAY, inserts a cue-in.
in IN-GRIDS, links an input to a track.
in OUT-MAPS, connects audio sources to outputs.

- [shift] [black] in REC, PPR, TEST talkback mic to active tracks.
in PLAY, plays from start of take.
- [gold] in REC, PPR, BROWSE, changes take-type.
in BLUE-PLAY, inserts a cue-out.
in IN-GRIDS, unlinks an input from a track.
in OUT-MAPS, disconnects sources from outputs.
- [shift] [gold] in TEST, PPR, REC, 1kHz reference tone:
'OFF' at [gold] release, remains 'ON' if [shift] released first, press [shift] to turn 'OFF'.
in BLUE-PLAY, hide play-card from Rec&Play list.



Starting & Stopping

To turn 'ON' Cantar, set the [MainSelector] to STOP, press the [batt L] or [batt R] button for a couple of seconds. The rectangular screen lights up to confirm that Cantar is powered. On the left circular screen, the 'three-platter' icon blinks for three to five seconds, the time it takes the disk to wake up; it is surrounded by the icons of the currently routed tracks. The rectangular screen displays batt-L and batt-R voltages, plus the system day and time.

To shut down Cantar, set the [MainSelector] to STOP, maintain pressure on the blue [shift] button and [batt L] or [batt R] until 'AU REVOIR' is displayed. As a safety measure, if you are not in STOP, nothing happens.

Reminder: while in STOP, internal HDD sleeping, the current drain is a mere 270mA. To keep the internal sync-clock running, do NOT turn 'OFF' Cantar during the workday.

Twin battery safety

Cantar's low power consumption electronics offer the longest operating time of all portable eight-track audio recorders. With a single set of onboard Li-Ion batteries, the eighteen hour Cantar outperforms all other recorders. And with the twin battery system you will never be taken by surprise. While in REC, both batteries are permanently put on duty, in case you unplug one by mistake.

Mains power supply

Only use a low ripple 15V/2A (16V max) power supply. NEVER use a battery charger, its idle voltage can go up to 24V: a Cantar killer.

While working on a cart from a mains power supply, leave a battery onboard and activate both inputs: the battery will buffer possible mains power problems, e.g. power cord accidentally disconnected, and it will supply the 4A surge at Cantar's start-up (off duty the rest of the time, thanks to the power supply higher voltage).

Voltage

Minimum: Each battery socket (Left & Right) gets its own **Batt Alert** level (TECHSET.14–15, p.34). This allows the simultaneous use of a NiMH battery with alert set to 10.8V, and a Li-Ion battery with alert set to 14.2V. Upon reaching the alert level, a two-beep alarm is sent to the headphones and the rectangular screen displays BATT L (R) LOW. When the active battery drops 300mv below the alert level both are put on duty.

Maximum: 16.6V is the maximum sustained voltage on any socket including the FireWire socket.

Never connect a FW cable coming from a desktop (e.g. MAC G3/4/5) delivering 30V. Extract the HDD (it can sustain up to 40V), and connect it directly to the desktop. Laptops deliver a safe 13V on their FW sockets.

Battery check

In TEST, [jog] to display the battery voltage; it also appears whenever you press the [battL] or [battR] button; pressing for more than two seconds puts that battery on duty.

Power Consumption

STOP 270mA (sleep mode), 420mA (HDD running)

TEST 600mA (AES Off, Phantom Off, Heater Off)

REC 650mA (AES Off, Phantom Off, Heater Off)

AES 100mA. **Phantom:** 10 to 20mA per mic (60mA total).

Heater 500mA until screens reach +4°C. **Ethernet:** 50mA.

Lithium-Ion

batteries The 14.8V/4.2Ah Aaton Li-Ion R-Cells are more powerful and lighter than their NiMH equivalent, 61Wh vs 45Wh, and 560gr vs 695gr. To avoid their destruction by NiMH chargers, the XLR4 plug pin-4 is protected by an 80V reverse voltage diode; pin-3 is directly connected to the cells; current is either flowing through the pin-4 diode to Cantars under #268, or through pin-3 to Cantars #268 up having the XLR4 socket pins 3&4 tied together.

charger Before plugging a battery, reset the Chascot five hour charger (Mascot 9940, Li-Ion 4-cell 2A) by pressing the square 'OFF' button for about four seconds until the LED totally vanishes (see chargers, end of this leaflet).

LED status: **red/orange**, two hour charge to 85% capacity; **amber**, three hour top-up; **green**, charged.

IMPORTANT NOTICE

• Flight rules: "NO Lithium-Ion batteries in stowed luggage. 1- Under 8gr of lithium content, carry on as many as you want within size and weight limits. 2- Between 8gr & 25gr, carry on no more than two batteries with a total lithium content between them of 25gr max."

At 5.8gr lithium, Aaton R-Cells fall within the first category.



Project, Day & Files

Error-free filing with NO disk partitioning!

When you cold-start Cantar, it assumes you want to continue working on your latest project, which is displayed at the bottom of the rectangular screen.

When you rent a Cantar, its project memory should be empty; the rectangular screen should display 'No Project'. Once created, a 'project name' regroups all data related to it, such as the days of recording, the tracks and the disks used. This name is stored in each audio file, there is no risk of a file getting lost in a maze of terabytes.

Unlike other machines, the Cantar file sorting system doesn't rely on disk partitions. Instead, it uses the 'Project/Work Day/Filetag' path tree, which allows for the intuitive and safe retrieval of any audio file on unpartitioned disks, anywhere along the PostChain. It is *not* operator-error prone.

1. Project

If you are in a bind and have no time to select a project in SESSION.01 'ProjectName' (p.36), go directly to REC, your audio files will be stored in a project named AACANTAR. Later, with Majax you will move these audio files out of the 'AACANTAR' folder and into the project directory you would have created in the mean time.

note: in their iXML chunk, the moved files still hold 'AACANTAR' as the Project Name. You will need to manually replace that provisional name with the correct name.

2. WorkDay folder

At startup Cantar asks: 'New Workday?', giving you the possibility to say 'NO'. Note that going to TEST or REC is a way to say 'YES'. The 'workday' is not the same as the actual 'time-of-day' as defined by the sync clocks, it is an interpretation of the 'human' day (see next page).

```

v13.5  V13.9
Sys 12:29:14
2005-03-22
    
```

The Cantar recorded files are multi-monophonic, i.e. independent files stored in a 'workday folder'.

That folder is automatically created at the start of each day and is named for the date, e.g. 20041206.AAD (see *Calender Time*, p.13). If the iso tracks must be interleaved before import into crippled editing machines in need of polyphonic files, Cantar builds an .AAP suffixed 'provisional folder' to momentarily store them (see BACKUP.13 'Erase Polys', p.41).

3. Filename

In 1997, the Aaton Indaw multi-track digital recorder introduced the Aaton filename system. Each filename consists of: a unique *filetag*; an optional *descriptor* that displays the scene, take-type and take; a *suffix* that indicates the type and sequence of the file.

The aim is to perform these tasks while remaining compatible with EDL standards which only handle '8+3' DOS filenames, and with Mac OS9 limited to 31 characters.

- The *filetag* (six character, automatically incremented index, i.e.AD1234) differentiates 6.7 million takes, a sound mixer's lifetime! (Indaw generates a 3 letter and 3 number filetag for 17.6 million takes). The filetag must remain untouched all the way through the final mix.

Each 'Take' generates a 'file group' sharing the same scene ID, take # and filetag, the filetag uniquely identifies and reunites the native iso tracks/files, e.g. AD1234 is the unique filetag of AD1234_1 to AD1234_8, of their associated polyphonic file AD1234PR, and of their poly mixdown AD1234PX.

- The *descriptor* displays the scene, take-type, and take #, e.g. scene A18:2a, take-type t, take 04.
- The *suffix* is used to flag the nature of the file, either multi-monophonic (_1 .. _8), or interleaved poly-Native (PN), or interleaved poly-Rotate (PR), or poly mixdown (PX).

Examples

A short filename: AD1234_1.wav

A long filename: AD1234==A18:2a t04==_1.wav

A questionable file?

Ask Aaton to give you access to their file-repair FTP site. If you don't have an ftp client, download the Mac-OS 'Cyberduck' freeware from <http://cyberduck.ch/> and for Win2K PCs <http://www.smarftftp.com>

An operational problem?

Go to TECHSET.03 'Save Setup', and create a Setup file to be e-mailed to cantar-support@aaton.com, this will help them solve your problem.



Calendar and Sync Times

Time is the essence of a digital audio recorder. Cantar uses two kinds of time: 'CalendarTime' organizes folders and files, 'SyncTime' links audio and picture.

Calendar Time

System date and *time* run on a medium precision clock which automatically creates the workday folders. This clock is powered for four to six years by a user replaceable 3V Lithium CR1220 button battery located below the HDD compartment.

In STOP, the system date and time displayed on the rectangular screen must be checked for a \pm five minute consistency with the time-zone you are working in; think of it when you get off of a three-hour flight.

This clock is very important for file management; go to TECHSET.21 'System Time' and press [ok], a triangle points to the modifiable digit. Using [jog], select the desired value, then press the [>] or [<] to move on to the next column, and so on, [ok] to exit. Power 'OFF' Cantar then back 'ON' for the CPU to use the new system time.

The *Workday* is related to the date defined by the calendar clock but not totally a clone of it. The workday is an interpretation of the 'human' day; its duration can be from 6 AM in the morning to 3 AM in the deep night next day. If you turn 'OFF' the batteries after midnight, Cantar thinks the operator has gone to sleep. But if your 'workday' is continued into the wee hours after a midnight snack, you would probably not want it to be considered a 'new' workday. That is why Cantar displays 'New Workday?', giving you the opportunity to say 'NO'. Note that going to TEST or REC is a way to say 'YES'.

Thus, if you stop working at 2 AM one day, the audio files are technically still part of the previous workday. Conversely if you want to start a new workday right after midnight, just turn 'OFF' Cantar, then back 'ON' and answer 'YES' or go to TEST.

Sync Time

At startup you will notice a blinking **int c** or **ext c** icon, depending upon the master (internal clock) or slave (external clock) mode selected in AUDIO/TC.13 'TC Source'. This blinking icon reminds you to verify that the same timecode is running in all of the camera(s) and audio recorder(s).

Four syncing methods can be used:

Method 1

'int c' internal **Free-Run** master-clock

Set AUDIO/TC.13 'TC Source' to 'Int.Clock'. The internal TCXO 1 ppm clock keeps the time accurate to within \pm one frame in nine hours; this time is used to stamp the sound files with the very same TC as the one stamped on the camera's images. This is the AatonCode method. In the video world they called it the **Free-Run** mode.. Once initialized (four ways) Cantar behaves as an independent *master-clock*.

- **System/Calendar initialization**

At startup, Cantar uses the System/Calendar date and time to immediately initialize its internal high stability, 1ppm TCXO, Sync clock, '**Stc**' (System-TC) is displayed in the rectangular screen. To remind you to sync other equipment around to the Cantar Sync clock, the '**int c**' icon keeps blinking until you press [shift] [TC jam]. 'Confirm Sys time' is displayed.

- **Operator initialization**

In case you don't want to use the calendar date and time, the TCXO clock can be set by the operator, see AUDIO/TC.18 'OperTc Init'. '**Otc**' (Operator-TC) is displayed in the rectangular screen.

- **LTC initialization** (from Camera, VTR, GPS, etc.)

Cantar on TEST, press [TC jam] for more than two seconds, this makes the entered SMPTE LTC jam the Cantar TCXO clock. '**Jtc**' (Jammed-TC) is displayed in the rectangular screen. [TC jam] has no effect if there is no valid timecode on the LTC inputs, '**Jam Failed No LTC**' appears in the rectangular screen and the '**int c**' icon continues to blink.

- **ASCII initialization** (from Aaton OriginC)

Cantar on STOP, its TCXO clock is set by an Aaton OriginC which also initializes cameras and GMT generators. '**Atc**' (ASCII-TC) appears in the rectangular screen.



Cantar becomes a master-clock

As soon as the **int c** icon stops blinking, Cantar starts generating timecode. This timecode is based on a TCXO (Temperature Compensated (X)crystal Oscillator), accurate to \pm one frame in nine hours (1 ppm). This high accuracy makes Cantar THE timecode reference on set.

If you turn 'ON' the LTC generator output in AUDIO/TC.15 'LTC Gen Out', the LTC output can be used to continuously sync all equipment through cable or RF. You can also initialize several Aaton GMTs (low power, high accuracy, timekeepers), attach them to the cameras and digi-slates and have TC that matches the Cantar's TC.

Do not power down a master-clock!

Being on a job on which the Free-Run time-of-day TC is the essence (AatonCode camera, HD camera with GMT reference generator, smart digi-slate), never power down Cantar during the workday to avoid the loss of its 1 ppm reference time! While the internal HDD is in sleep mode the total power consumption is a mere 270mA! Set TECHSET.16 'HDD Pwr Dwn' to 'Afr 5min', to have the HDD sleep five minutes after STOP. If you still want to power down Cantar at lunch time, the blinking **int c** icon at power up will remind you to re-initialize all other timekeeping machines on the set.

Method 2

'int c' internal **Record-Run** driving clock

Go to AUDIO/TC.17 'RecRun Init', [ok]: 01:00:00 is proposed as the first TC of the day (it can be modified). From now on, at the beginning of each audio file Cantar will stamp a start-TC incremented by two seconds later than the preceding take's end-TC. This clocking, called Record-Run, produces audio files which appear as if they have been recorded in continuity.

If for some reason Cantar is turned 'OFF', the Record-Run TC must be initialized again. To prevent any TC overlap, Cantar proposes to start on the next hour integer, e.g. if the last recorded take has been closed at 01:34:15, the next start-TC proposed to the operator will be 02:00:00.

The Cantar Record-Run mode lets you use the pre-record buffer without creating TC overlaps. For example, if the preceding take ends at 01:45:00, and the pre-record buffer is set at thirteen seconds, the next audio file will start at 01:45:02

(two second gap), but the LTC emitted by the generator to the camera when hitting REC will be 01:45:15.

While Cantar is in Record-Run mode, its reference TC must be continuously sent to all cameras on the set by wire or RF.

note: in TEST and PPR, the LTC output is frozen on the end-TC value, it can thus be used as a master TC to start and stop another Cantar (see *Record by LTC*, p.21).

Method 3

'int c' internal clock, **AutoSlate** on clapsticks

If the same TC is not running in Cantar and cameras, the only way to sync pictures and audio is to use clapsticks; forget digi-slates, they have too many drawbacks. The Cantar AutoSlate sample-accurate clapstick detection function puts a timecode crown over the simplest piece of wood (p.23).

Method 4

'ext c' **slaved** to an external clock

An externally-slaved Cantar stamps the audio files with the same TC as the one running in the video camera. This requires a link from the camera to Cantar.

Set AUDIO/TC.13 'TC Source' to 'Ext.Clock'; **ext c** blinks in the circular screen, meaning that Cantar is waiting to be slaved to an external LTC, e.g. a video camera. *Cantar, while set to 'external clock', will only jam when you go to REC; pressing the [TC jam] button will do nothing.*

Cantar is usually in REC before the camera, so it monitors the Lemo 5/SubD 15 incoming LTC and grabs it when coherent TC is received. That is why **ext c** keeps blinking until the camera is up to speed.

Before closing the audio file, Cantar stamps the TC by using the latest valid timecode so as to eliminate spurious transmission errors and false camera starts. If there is no external timecode signal, an 'LTC Not Detected' warning appears in the rectangular screen and a phone beep is triggered every four seconds. The beep is muted during 'w' (wild track) tagged takes (see *Warning beeps*, p.22). Nevertheless, the external TC is grabbed if it is received before the take's end.

note: external LTC breaks can be used to slave the REC start and stop (see *Record by LTC*, p.21).



Sampling Rate, Camera fps, Audio-TC

These parameters are not correlated. The number of audio samples per Earth second (Hertz), is called the sampling rate, e.g. 48000 is 48kHz. The camera 'frames per second' value should have no influence at all on the audio sample rate frequency; unfortunately, some vintage NTSC post-machines still impose the use of the disgraceful 48048 or 47952 sample rates to sync real-time audio with drifting-time images. The frame-rate used to express the audio time can be 30, while images are filmed at 24 or 25fps.

On the planet Earth

Timecode handling is simple at integer speeds such as 24, 25 and 30fps; *at 29.97DF (Drop-Frame) the frame count jumps over two images every minute except for every tenth minute to keep the count in line with Earth's time.* Stored in the file metadata, the camera fps is a simple reminder and can be changed later and then applied to the audio LTC used in some audio-post sync operations.

'U' Universal : 24.00, 25.00, 30.00, 29.97DF

In a file digitized at 48kHz, the Format stamp indicates the number of samples per real-second, i.e. 48000; the Time-stamp carries the number of samples since midnight using the sample rate value found in the Format stamp (*the same logic is used in the Barebone mode-B for 'slow-planet' recordings*).

On the 'slow-planet'

Unfortunately, NTSC-compatible 23.976fps HD cameras cannot use the anti-drift drop frame system because nobody found a way to emulate the counting drops invented for 29.97fps. In this environment the 'slow-second' (*the time it takes to shoot 30 frames of NTSC video, i.e. 1.001 Earth second*) imposes its rule.

As soon as you enter **Camera fps = 23.98NDF** or **29.97NDF**, you are on the 'slow-second' planet, with its lazy 24 (aka 23.98fps on Earth) or lazy 30 (aka 29.97fps on Earth). The Cantar's TCXO clock switches to a slower beat and TC separators change from ':' to '*', e.g. 12*45*36.

Many nights of engineers' time have been spent trying to find a universal method to sync sound and images on the slow-second planet but nothing came out. In the U.S. you must ask your post-facility which one of these *three sample-stamp modes* is requested:

'A' Avid v11: '23.98NDF-A', '29.97NDF-A'

In a file digitized at 48kHz, the 'A' Format stamp indicates the number of samples digitized in a slow-second, i.e. 48048; the Time-stamp is the number of samples since midnight, using the 48048 value of the Format stamp.

Introduced for the AvidMC v11.3.2, the 'A' mode is fading away. See 'Avid-Recording-Rates' in Aaton tutorials <http://www.aaton.com/documentation/>

'B' Barebone: '23.98NDF-B', '29.97NDF-B'

In a file digitized at 48kHz, the 'B' Format stamp indicates the number of samples digitized in a real-second, i.e. 48000; the Time-stamp is the number of samples since midnight using the 48000 value of the Format stamp.

While images and timecode are beating the slow-second, the audio remains on Earth! Since modern post-machines (e.g. Indaw) perform high quality real-time sample rate conversion, 'Barebone' and 48kHz should have been THE only choice but unfortunately some other manufacturers decided differently (see below).

'C' Compensated (F) Faux: '23.98NDF-C', '29.97NDF-C'

The 'C' mode is made for challenged post-machines. In a file digitized at 48kHz, the Format stamp value indicates the real number of samples per real-second, i.e. 48000, and the Time stamp is the number of samples since midnight **as if** the digitization was done at 48048!

Hence the 'F' name (for Fake or Faux) given by Fostex and FCP to this mode. This is the mode selected by most US productions.

If it is 02h00m00s on Earth at the start of take, the Time-stamp value is 345,945,600 samples (02h x 3600s x 48048).

Summary Cantar set at 23.976NDF or 29.97NDF, select:

'A' mode: Actual recording sample rate 48K. Sample rate noted in the file 48048. Time-stamp calculated using 48048.

'B' mode: Actual recording sample rate 48K. Sample rate noted in the file 48K. Time-stamp calculated using 48K.

'C' mode: Actual recording sample rate 48K. Sample Rate noted in the files 48K. Time-stamp calculated using 48048.



Audio inputs

Analog inputs: symmetrical, transformer isolated mic1 XLR3, mic2 XLR3, mic3 & mic4 XLR5, mic5 XLR3, and asymmetrical line-in1 & line-in2 XLR5, line-in3 & line-in4 XLR5.

AES inputs w/ individual sample-rate converters: digi-in1 to digi-in8 Tascam SubD25 (see p.57).

Microphone preamps

Cantar's mic-preamps offer such a wide dynamic range in one single stroke that they don't need any pre-conditioners or trims. Whenever you adjust a fader, all inputs for that type (line/mic) are displayed (in dBFS) on the rectangular screen.

Phantom power

Press [shift] [so-fil-tom] (2) to toggle that mic's Phantom 48V power 'ON/OFF'. The default setting is 'ON'; turn it 'OFF' while using a dynamic microphone. The preamp gain will be boosted by 12dBu, and the triangle below the mic number will disappear from the right circular screen.

Limiters

Press [lim-inv] (1) for one second to toggle the limiter 'ON/OFF' (to protect the limiters from mistaken fingers, a

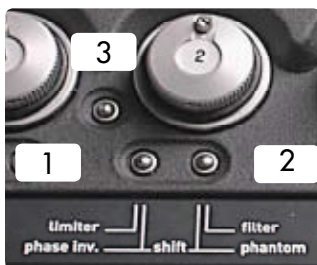

one second pressure must be applied). While the limiter is turned 'ON', a triangle is displayed below the mic number on the left circular screen. If the signal level reaches the limiter zone (-8dBFS), the

triangle will start blinking. In 24-bit recording mode, it is common practice to adjust the input gain so that a 'normal' signal does not go over the -20dBFS level. Limiter activated, the 32dBu head-room above the -8dBFS kick-in point gives 24dBu above the 'no-limiter' full scale. The operator can count on a 44dBu reserve over the normal -20dBFS level. If the signal does reach the -1dBFS level, a 'clip' icon appears at the end of the modulometer scale and a beep can be sent to the headphones (TECHSET.08 'Clip Detect'). To maintain equilibrium between linked channels, the same limiter command is applied to ganged preamps.

Inversion

Press [shift] [lim-inv] (1) to invert the phase of a mic signal; a triangle appears below the concerned mic number on the middle circular screen.

High-pass filters and line attenuators

Click the [so-fil-tom] button (2) of a mic to open the filter selection screen, another click on any [so-fil-tom] button closes it. In between these two clicks you can [jog] through the filter selection screen. Continuously leaving the finger on the [so-fil-tom] button simulates both clicks: when you remove it, the filter screen closes itself.

Three **banks** are displayed in the rectangular screen, they offer the same corner frequencies/slopes (from 60Hz/-6dB to 180Hz/-12dB and LFA).

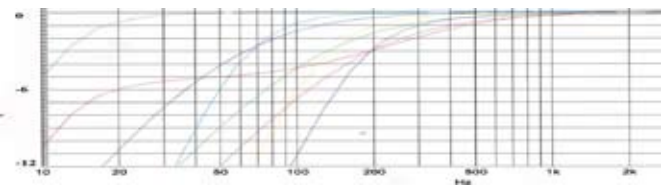

To avoid mic preamp saturation by non audible ultra-low frequencies, always insert a high-pass filter when a bass sensitive mic such as an MKH8050 is installed on a moving boom, the use of a very efficient wind jammer is paramount.

- Mic Level:** default for all mic inputs.
- High Level:** an 8dBu command offset puts the fader knobs in the same angular position as when a standard sensitivity mic is used.
- Line Level:** a 24dBu attenuator converts mic to line inputs (available on SL1 preamplifier, Cantars from #268).

Differential delays

Cantar-X2

Delays inherent to sound propagation (3 ms/m) or induced by signal processing (up to 3.8 ms in a digital wireless kit) can induce 'phasing' interference between mics placed at different distances (or time) from a sound source. In some instances it is advisable that all other audio inputs contributing to the onboard mixdown wait in a buffer for the 'late-sound' arrival. In TEST, press [shift] [silver] to open

LVL&DELAY 03
mic1 delay
78.8ms

LVL&DELAY, [jog] from 03 'mic1 delay' to 11 'line4'; press [ok] on the one to set, [jog] from 0.0 to 85.0ms delay in 0.1 ms increments i.e 5 audio samples (1 ms increments by [shift] [jog]). Fine tune the delay by listening to the tracks in 'double-solo' (see *Soloing tracks*, p.22). An ear protecting mute is applied during delay modifications.



The value of the longest delay is applied to all channels except for the one being set; example: a digital wireless lavalier (3.8ms processing delay) feeding line1 must be in-phase with a boom at 6m distance (18ms sound propagation time) feeding mic5: set mic5 at 18ms and line1 at 3.8ms. All analog inputs are buffered by 18ms, line1 by (18 – 3.8) 14.2ms, and mic5 by 0.0ms.

Since the delays can go up to 85ms (two film frames), the TC stamp in each audio file is corrected accordingly; for this reason, each input delay is noted in the iXML chunk and the CSV Sound-Report file.

Gain values

Set TECHSET.06 'Display dB' to 'ON'; whenever you adjust a fader, all inputs for that type (line/mic) are displayed (in dBFS) on the rectangular screen.

Mic links

The links are preselected in AUDIO/TC.08 'Mic Links' (p.31),

Stereo-pairs: pre-select 1 > 2 & 3 > 4

Surround sound: pre-select 1 > 2.3.4.5

Double M/S: pre-select 3 > 4.5 (p.44).

To active the preselection, press the [shift] [link-lock] button to the right of the master fader; a (||||) appears between the linked mic figures in the bottom of the circular screens.

Phantom, Limiter and Highpass filters are applied identically to the linked faders. Phase inverters remain independent. The slave tuning range is ±12dBu of its master's value. Whenever you adjust a fader, the master/slave status is displayed on the rectangular screen as (|| ||) for the master, (||) for each slave ((coming soon)).

All of these links remain active when the onboard faders are taken over by the **CantaRem** RemFaders.

Protecting the balances

To protect the 'balancing' faders against flying fingers, set AUDIO/TC.07 'BalanceLock' to 'Locked'; balance modifications will be unlocked while pressing the [so-fil-tom] button (2). The slaved gain value is displayed with (<) (|) (>) signs showing in which direction you should rotate the fader to avoid any sudden level change when unlocking the balance key.

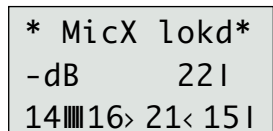

Line links

The links are selected and armed in AUDIO/TC.09 'Line Links' (p.31). For Surround sound recording with a Soundfield ST350, use the line1 fader as the master of the two other line

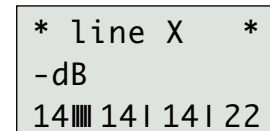
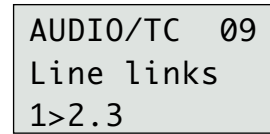

inputs: set 'Line Links' to 1>2.3. Slaved line faders (|) have no balancing activity, they get their gain value from the master (||||).

The T1-T6 Mixer

The mixer's pan-pot and fader controlled outputs are called Xa (left), and Xb (right).

Pan-pots

Each recorded iso track can be sent to Xa or Xb or both. Push the [SoloMixPan] to PAN (battery side), press the [track solo] button and [jog] the pan marker toward the left or right side of the circular screen (p.7). The value in dBFS of what is left to the other side is displayed on the rectangular screen. When a track pair is declared 'm-s', its pan markers go to the middle, the M & S signals are recorded as they are but they are L/R decoded into the mixdown and the phones. For the line-out, foldback and digi-out, see M/S monitoring, p.18.

Faders

The pan-pots being set, each iso track's contribution to the mix is adjusted with the faders. The maximum gain can be either +6dBu or 0dBu (see AUDIO/TC.05 'MixGain Max', p.31).

Outputs

Recorded on T7T8 or not, Xa/Xb (left/right) can be sent to the external world by selecting the XX Out-Map in the Ph, Lo, Fb and Do positions of the [monitor] crown. Recorded on T7T8 or not, the Xa (center), Xb (center), Xa+Xb (center), Xa/Xb (left/right) mixer outputs can be phone monitored in TEST, REC and PLAY in the So position of the [monitor] crown; their level is displayed on the central circular screen.



note: when the Xa Xb mixer outputs are recorded on T7T8, their levels are displayed on the rectangular screen bargraphs (p.8).



Check and select the routings

In TEST, PPR and REC, depending on the [SoloMixPan] slider position, the [routing] button activates the display



of the input routing templates called *In-Grids* or the output routing templates called *Out-Maps*. This is done by continuously pressing the [routing] button or by a short click to open, another click to close; this later method liberates the thumb to better grip the crowns.

In-Grids

To check and select *In-Grids*, **PUSH** the [SoloMixPan] slider to the battery side and press the [routing] button. The silver [config] crown gives sequential access to fifteen *In-Grids*, the last in use is displayed first.

To protect the recording's integrity, you can't change *In-Grids* while in REC, but you can do it with a trick: go to PPR, press the [routing] button, rotate the silver [config] crown to the desired *In-Grid*, release the [routing] button and go back to REC, the pre-record buffer gives you up to thirteen seconds to act... not one single audio sample will be lost between the two audio files.

Out-Maps

To check and select the *Out-Maps* for each **Ph, Lo, Fb** and **Do** outputs, **PULL** the [SoloMixPan] slider to the operator's side, press the [routing] button and rotate the black [monitor] crown. To browse the preset *Out-Maps* and select one, rotate the silver [config] crown, the active map will be the one displayed when closing the [routing] command.

You can select different *Out-Maps* while recording, this doesn't affect the recorded signal.

note: in PLAY, the active *Out-Map* can't be displayed, verify it on the [MainSelector] ROUTING position.

Rec&Play rehearsal

(read p.48 & p.49)

In BLUE-TEST, the playback tracks (Tp1 – Tp8) are sent internally to the digi1–8 inputs, from where they are routed the standard way. By pressing [routing], select the *In-Grids* and *Out-Maps* tailored to the job. Rehearse the BLUE-REC navigation and with the analog faders, adjust the levels between the digital play-cards and the live (analog) inputs. The last BLUE-TEST played card is the first to be called when going to BLUE-REC.

Track (dis)arming

An advantage of the monophonic multi-track file recording is to not waste disk space by recording empty tracks as is the case with polyphonic files. It is wise to momentarily disarm a track when there is no use for it. In TEST, press [shift] [track-solo] of the unwanted track. Its monitor is muted and as a reminder, its track icon blinks and its modulometer is dashed. Disarmed tracks are not inadvertently rearmed by going to PLAY or BROWSE, you must go to the ROUTING position and back, or turn 'OFF' the power.

M/S monitoring

The 'm-s' declaration of a track pair (IN-GRIDS, p.27) causes them to be decoded as m+s/m-s, i.e. L/R stereo in the phones and mixdown. If on top of the phones, you want an M/S recorded track pair (say T5T6) to be sent as L/R stereo to the Lo, Fb, Do outputs, create an *Out-Map* in which T5 goes to the left and T6 to the right, Cantar will *automatically* decode these M/S tracks as L/R. This applies to the T1T2 and T3T4 pairs too, alone or together. ***Panning the M track to the left or right, makes it go there, and the S signal disappears from the mix. That is a way to mono monitor the M signal.***



Headphone level

The headphone level is protected by [shift] and is displayed on the rect. screen. Rotating the fader makes '<' and '>' appear. There

is no level change if [shift] re-activation is done while the fader is put back in its 'pipe' (|) position. The headphone amplifier can drive 8-ohm speakers: a helpful feature to send playback tracks to the stage. To facilitate extraction of a right angle 1/4" jack plug, the phone socket is slanted toward the bottom of the machine; beware, this makes a long straight plug hit the cart desk.

Line-out and Foldback levels

In TEST, open LVL&DELAY with [shift] [silver]. The line-out and foldback levels are [jog] adjustable from 0 to -94dB and Mute. A -18dBFS tone delivers a -10dBu line-output compatible with HD cameras' line-inputs.

```
LVL&DELAY 01
LineOut lvl
-20 dB
```

CantaRem faders can be assigned to line-out and foldback level command too (p.53). A two channel +12dBu transformer accessory is available (p.57).

note: insert a 12k ohm resistor in the input path of the Senheiser transmitters to avoid oscillation and noise generation.



The **Pre-Post-Record** position is unique to Cantar, it offers three essential functions: pre-record buffer activation, meta-data entering/editing and last take erasure.

Pre-record buffer

While the [MainSelector] is on PPR, the pre-record buffer stores the audio in a First-In/First-Out (FIFO) buffer memory and dumps them to the HDD as soon as REC is activated. The '●rec' icon blinks under the disk(s) selected for recording. Once the buffer is full, up to 13 sec. @ 48kHz, it starts discarding the First-In audio, the middle platter of the 'three-platter' icon disappears; this is a way to verify the selected buffer length (AUDIO/TC.06 'PreRec Dur', p.31).

Pre-Rec metadata entry: 'NEXT take'

While in PPR, enter/edit the scene ID, take #, comments, track-names and Audio-Ref of the NEXT take, then press [ok] to validate. *Two remarks:* – the use of Arcan, Tarkan or keyboard considerably speeds up metadata entry; – [shift] [jog] accelerates letter scrolling 10x.

1 Scene and Take

The first screen displays 'Seq Scn Tak'. Press [ok] to go down to the bottom line and use [>] or [<] to scroll along the characters and modify them with [jog]. Press [ok] to store and exit.

- The default template is **nnnA/nnA.nn** for 'sequence, scene, take-type and take #'.
 - **Sequence:** three digits, followed by one character*.
 - **Scene:** two digits, followed by one character*.
- *'space', 'A' to 'Z', 'a' to 'z', '0' to '9'.
- **Take-type:** t = *time* synced, p = *pick-up*, w = *wild* track, a = *announce*, n = *ignore* (keeps the take # for the next file). This list (*tpwan*) is scrolled with the [gold] button.
- **Take #:** two digits.
- An open **CCCCCCCC.CC** template is also available, (see AUDIO/TC.10 'ScTk Templt', p.31).

At each new take, the sequence & scene is maintained and the take# is incremented by one. Modifying the sequence or scene ID causes the take# to reset to '1', and the take-type to 't'. The rectangular screen displays the filetag of the NEXT recording.

2 Comments

[jog] to 'Tk Comment' and press [ok] to activate the bottom line where the former comment appears. Characters (max: 200) can be entered with [<], [>] and [jog] but it is much easier to use a keyboard or a remote PDA with Arcan. Depending upon the keyboard [insert] key toggle status, a flickering square (insert) or a flickering pipe (overwrite) is displayed. Enter your comments. and press [ok] to validate. *note:* to erase the comment line inherited from the preceding take, press [shift] [esc].

3 Track-names

[jog] to 'TrackName 1', [ok] to go to the bottom row. [shift] [jog] or keyboard's [shift] [up/down] arrows show the available list of track-names.

Track-name completion relies upon a library of the last thirty track-names in use. This automatic process speeds up track-naming by letting you pre-store the names of the film's main actors and swiftly recall them by their first two letters. Press [ok] or [enter], and [jog] to 'TrackName 2', etc.

Track-names are modifiable at all times and are stored in each and every audio file, this means that an isolated file carries its own track-names.

Library cleaning

By [jog]-ing past 'TrackName 8' you reach 'Del TrkName', [ok], select the track-name to be erased, [ok]. If you decide not to erase it, press [esc]. In a bind and no time to name the tracks of the next take, it is better to remove the former take's track-names than to carry incorrect ones in the next take.

Go to the track-name editing line (any track will do), and press [shift] [esc]; the following generic names will replace them: **T1** to **T8** on native monophonics; **ms-M** and **ms-S** on M/S tracks; **MixRight** and **MixLeft** on mixdown tracks.

Press a [track-solo] button to display that track's name in the rectangular screen.

note! to allow for a possible entry from a PDA, the generic track-names above are only recorded upon completion of the take.



note2: the default entry mode is 'overwrite', if you change it by selecting 'insert' on the keyboard, it will revert to 'overwrite' on the tenth character since track-names are limited to this number.

4 User's Tape Ref

You can overwrite (*not recommended!*) the automatic Cantar generated MMDD *Usr TapeRef* with either the project's incremental "Shoot Day Number", or something like the VideoTape ID, later called "Roll Number" on the Avid (p.47).

Post-Record metadata entry: 'PREVIOUS take'

After REC, stay on PPR, the metadata to be used for the next take is displayed. If you want to modify the just recorded take's metadata, press [shift] [silver].

The rectangular screen displays EDIT, press [ok] then [>], [<] or [jog] to edit the PREVIOUS scene ID, take # and take-type ([gold] button) of the previous file as explained in 1 - 4 (above).

Press [ok] to confirm, then [shift] [silver] to close.

Pazienza! paciencia! patience!

When editing metadata entries, you are modifying the native files stored in the internal HDD. If you are working in simultaneous (mirroring) mode, these modifications are immediately applied to the external drive files as well. But if you are working in **IdleCopy** mode, they will only be applied later when Cantar is in TEST or STOP position.

So, at the end of the session, remember to not unplug the external HDD nor to remove the DVD-RAM disk in haste. Wait until **IdleCopy** finishes its revamping work!

Manual file splitting

To divide a file into shorter segments, quickly go from REC to PPR and back to REC. A new file is created; it carries the same scene ID and the take # is incremented. You will not lose a single audio sample. A short pre-silence is added at the head of the new file to ease the splicing work in Post. By setting the PPR buffer to a long enough duration you can even enter new scene and take IDs and comments.

Automatic file splitting

If you need to record audio during very long periods without interruption but you don't want files larger than 4GB, Cantar automatically closes the file and starts a new one: four settings are available: **260MB** (e.g. 1 track for 30 min @24-bit/48kHz), **690MB** (700MB CD-R capacity), **2GB** (default setting), **4GB** (FAT32 max. filesize). The filetag is incremented but the scene and take IDs remain the same.

Last take erasure

To save disk space, Cantar lets you erase the last take, e.g. a *false start* or *aborted remix*. In PPR, press [shift] [silver], to open 'Edit prev.', [ok]; select 'Erase Take'; toggle from 'No' to 'Yes', [ok]. For protection, the latest position must have been REC, and the power must not have been turned 'OFF'. The next take will carry the same take ID as the erased one.

False start

If you are under pressure, and not willing to risk an unforgiveable mistake, do not erase a false start as described above, *stay in REC*, press the [gold] button until 'n' (for ignore) from the take-type list 't p w a n' is selected, then go to PPR. The next take will carry the same take # as the ignored one. Takes with a take-type of 'n' are greyed in the PDF sound report and carry an '*aborted/false start*' header in the 'comment' line.



Record by LTC

This function is also called 'Remote Roll', 'Auto-load' or 'Remote record' depending on the country and manufacturer.

Select AUDIO/TC.12 'Rec by LTC' (p.32): Cantar starts recording upon receiving **running LTC-in** and stops recording upon receiving **frozen LTC-in** generated by a video camera or an Aaton GMT (see *Remote roll*, p.55).

note: the source for timecode stamped in each audio file is either the Cantar's master TC (**int c**), or the remote master clock's TC (**ext c**).

The remote LTC can carry a continuous Record-Run TC or a discontinuous Free-Run time-of-day TC. No time overlaps are created on the breaks since Cantar waits for three seconds to validate the new LTC then goes to REC while splicing the preceding three second audio stored in the pre-record buffer.

If you want to continue the recording knowing the video camera is about to stop, swiftly switch from PPR to REC.

Remote by Aaton accessories

Tarkan Ethernet connected Mac or PC, CantarX2 (p.51),

CantaRem eight linear fader surface (p.53),

Arcan-w Bluetooth connected PDA (p.54).

Remote by keyboard

In PPR, Cantar can be controlled by a PS2 **keyboard** through a *USB-PS2 to SubD 15* converter (p.57).

Simultaneously press [ctrl], [alt] and one of the following:

- | | |
|--------------|---------------------|
| [r] = REC | [g] = IN-GRIDS |
| [p] = PPR, | [m] = OUT-MAPS |
| [t] = TEST, | [a] = AUDIO/TC |
| [s] = STOP | [k] = TECHSET |
| [l] = PLAY | [c] = BACKUP (Copy) |
| [b] = BROWSE | [j] = SESSION |

Use the vertical arrows or the numeric pad to scroll the parameters, use the horizontal arrows to select the parameter value, press [enter] for 'ok', [escape] for 'esc'.



Recording

In REC, a '● rec' icon is displayed under the active disk drive and a red LED lights up underneath this icon. While in REC, both batteries are paralleled for additional safety.

Iso Track modulus

In REC, PPR and TEST, the modulometers display the level of the signals to the tracks. The circular modulometers' resolution is 1dB in the -35dBFS to -12dBFS working zone. The rectangular screen modulometers' resolution is 2dB in the same zone. The ballistics emulate needle modulometers. The decay time can be adjusted in TECHSET.12 'Meter Speed' from '1 Fast' to '5 Slow'. In a low temperature environment, '5 Slow' is recommended. The default is '3 Med'. The peak meters are always active, and their 'hold' period can be adjusted from one-half to five seconds (TECHSET.13).

Soloing inputs

To monitor a questionable input, rotate the [monitor] crown to **So** and select the desired input. You can also directly monitor a microphone by pressing its [so-fil-tom] (2) button or make a short click to turn it 'ON', another click turns it 'OFF'. While [so-fil-tom] is enabled, its filter setting can be modified using [jog].



Soloing tracks

Pull the [Solo/MixPan] slider to Solo (operator side). Press a [track-solo] button, you will hear the track's audio in both ears. While maintaining pressure on a solo button, press another one. You will hear the first soloed track in the left ear, and the second in the right ear. Use this feature to compare track levels, phases or differential delays. When a [track-solo] is activated, the selected track's modulometer is differentiated from the others by a 'dashed' appearance.



Locking all Faders

Press the [link-lock] (3) button (between mic 1 & mic 2 faders) to (dis)able the mixer's linear faders; press the [link-lock] (3) button (between mic 3 & mic 4 faders) to (dis)able all rotary

faders. Any action on a disabled fader causes the rectangular screen to display 'Locked Fader' instead of its gain value. To prevent inadvertent (un)locking, the button must be pressed for a full second for the action to occur.

Reference Tone generator

In TEST, PPR or REC, [shift] [gold] sends a 1kHz tone to the tracks, modulometers and mixdown. '-18dBFS' or '-20dBFS' is selected in AUDIO/TC.03 'Tone Level'. Releasing [shift] before [gold] locks the tone 'ON'; pressing [shift] turns it 'OFF'.

Talkback mic

In TEST, PPR or REC, press and hold the [black] button to send the talkback to the left channel (see AUDIO/TC.04 'TalkbackMic'); quickly press [black] then press and hold it to send the talkback to the right channel. Press [shift] [black] to send the talkback to all tracks.

Warning beeps

The beep level is set in TECHSET.11 'Beep Level'. **One beep:** record start (07), clip detection (08). **Two beeps:** record stop or low priority problem such as low battery voltage; the 'Lack of external clock' (09) is automatically disabled on 'w' (wild track) takes. **Three beeps:** high priority problem, e.g. unplugged external HDD.

Take-type

Press the [gold] button to scroll the 't p w a n' take-type list: *t* =time sync audio, *p* =pick-up, *w* =wild track, *a* =announce, *n* =ignore. The 'n' takes are greyed in the PDF sound report, and "aborted take/false start" appears in the comment line.

note: in case of *false-start*, stay in REC, press [gold], select 'n' in the tpwan list, then and only then, go to PPR; the next take will carry the same take # as the 'ignored' one.

Going to PPR (p.20), you could open the PREVIOUS edit process to do the same, and even erase the take to save disk space, but this takes more time, and this is not recommended in the high pressure short time interval following a false-start.



Record tally & SD remote

In REC, the SubD 15 pin-11 is grounded by an open collector transistor (max: 40mA). Do NOT use a coil activated device on pin 11, the flyback voltage would kill the transistor. Use an opto-coupler (see drawing) to avoid ground loops.

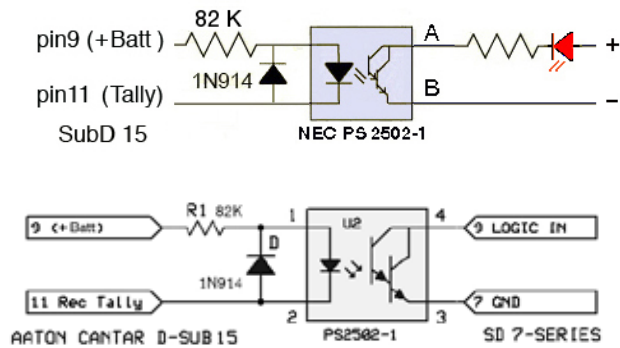

AutoSlate

This is the most precise and simplest method ever invented to sync images and sounds (p.46).

In AUDIO/TC.11, select the slate detection channel.

While in REC, press [shift] [silver] within six seconds after a clapstick; the most plosive event preceding [shift] [silver] creates a Slate Mark. The successive slates generated by a multi-camera shoot are labeled SA, SB... SG, the slate TC is displayed in roman characters in the Sound-Report.

The clapstick quality is displayed in the rectangular screen, 25% should be a minimum; at 75% score, you can congratulate the slateman!

If you forget to press [shift] [silver], AutoSlate detects the most plosive sound of the take with a 95% chance of selecting the clapstick; in this case the Sound-Report's Slate-TC appears in 'Italic' to show it must be either confirmed or ignored.

While in PLAY, [shift] [silver] starts the playback two seconds before the slate-mark. Majax displays an upright slate icon on start-slates and a bottom-up icon on tail-slates; click the icon to listen to the slate announce.

User's markers

Press the [silver] button to create tabs labeled UM1, UM2... UM10 on wind clicks, boom noise, dialogue slip, etc.. While in PLAY they are accessible with the [silver] button.

BLUE-REC

Rec&Play Live

see p.48

- Standard Playback and ADR1

Don't forget to route the digital input(s) carrying the playback signal(s); the analog inputs are recorded in the stan-

ard way. To launch the first play-card, press [ok] (if you are using a keyboard, press [space]). To stop before reaching the cue-out, press [ok]. To replay from the cue-in, press [ok]. To pause, press [esc], to resume, press [esc].

To reach the play-cards, two methods are available:

- the bare bone, where [shift] [>] browses the play-files, and [>] browses the play-cards.
- the easiest, connect a PS2 keyboard, type the card IDs (B12, F45, A08) and [enter]. Or use Tarkan, p.51.

Rec&Play Clone

see p.48

Remix, ADR-2, and Re-Rec

Don't forget to route the digital input(s) carrying the playback signal(s).

Go to BLUE-REC, the last selected play-card of the Clone-X Play-file starts playing. To abort the on-going 'cloning', go to PPR, erase the file (Last take erasure, p.20) and return to BLUE-REC.

Continuing to record live audio after the end point of the cloned take generates a file which is longer than the original mother file at the risk of overlapping timecode with the next take. To get a clone of the same length as the original, i.e. same start and stop TCs: go to BLUE-PPR and trigger the cloning with the keyboard [ctrl] [alt] [r]; the recording will stop on the original file's end.

Bad remixes

You can hide unsatisfactory remix(es) as well as the original file, and only send the good one to the backup media: go to BROWSE, 'edit' and 'trash'. If need be, you can rescue them later from the day's folder still stored on the internal drive.

Rec&Play sample-rate

Rec&Play only works at 48kHz ±0.1%. If there is a discrepancy between the play-file sample rate and the Cantar recording sample rate, a message (e.g. 'PF-47952Hz/Rec-48000Hz') is displayed. You can nevertheless proceed to BLUE-REC: the playback files will be played at the 'Live' recording sample rate, inducing a speed change which can be quite useful on filmed music shows transferred to NTSC.



Play commands

- [ok] starts/stops & sends to cue-in
- [shift] [ok] displays digitization parameters and TC fps
- [<] [>] go to prev/next play-card (or file if no card)
- [shift] [<] [>] go to prev/next play-file
- [esc] pause/resume
- [shift] [esc] toggles continuous file-to-file play, in PLAY only
- [black] cue-in, volatile in PLAY
- [shift] [black] sends player to start of take
- [gold] cue-out in BLUEPLAY; erases cues [jog]ed to 00:00
- [shift] [gold] hides play-card from Rec&Play list
- [silver] sends player to record-entered markers
- [shift] [silver] sends player to AutoSlate marks
- [jog] scrubs audio
- [shift] [jog] accelerates scrub 10 x
- [eye] displays tracks 5/6 or 7/8 on right screen
- [shift] [eye] toggles filetag-duration/scene-take (pref. stored until Cantar is turned 'OFF'). N.A. in BLUE-PLAY.
- [TC jam] displays elapsed-time or absolute-TC

Rectangular screen

- 1 A01 play-card label; * hidden from Rec&Play list.
- 2 > normal speed; |||> pause; -> non-stop play; 'ml' user record marker; 'sA' autoslate marker; ■■■ stop (end of file).
- 3 cue-in (volatile in PLAY).
- 4 scrub position [jog].
- 5 player pos. (or absolute time [TC jam]).
- 6 filetag (or scene [shift][eye]).
- 7 cue-out (or take [shift][eye]).

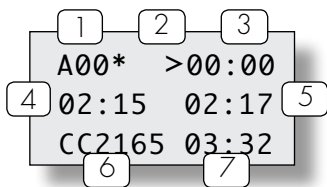

notes:

- the displayed mm:ss time is relative to the start of file, the file absolute TC appears by pressing [TC jam].
- in PLAY and X00 (1), the cue-in (3) is volatile, i.e. not stored when exiting; the out-point (7) is the end of file, i.e. the duration.
- in scrub, each [jog] tick moves the player by one second, delivering very intelligible forward and reverse dialogue.
- to edit 'scene & take' entries, scrub over the autoslate mark, listen to the announce, then go to BROWSE.
- to read the size of one track of a group, go to BROWSE.
- the LTC output carries the TC & fps of the play-file, not the project TC, it can be used to slave a chasing VTR.

Reminder: when going to PLAY or BLUE-PLAY, take your time while passing over STOP; if the message 'you were too fast' appears, go back to STOP for one second.

Play-card creation

read p.48 & p.49

1- Go to BLUE-PLAY (note1), then [shift] [>] to choose a Playfile among indexes **A** to **L**, the file index is displayed in (1).

2- With [<] or [>], select an empty card, e.g. **A01**, among the fifty-one cards per file. A00 (the factory card) is not empty, it contains the entire play-file; it can't store a cue-in, its cue-out (7) is the duration of the take.

3- To fill an empty card, scrub the audio with the [jog] (4), press the [black] button to set a cue-in (3), scrub further and press the

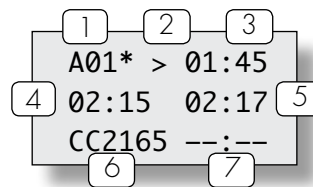

[gold] button to set a cue-out (7); a half second silence is inserted at the cue-out to let you detect and fine tune its position. The last entered cue points replace the former ones.

Once a cue-in has been entered (a cue-out is not necessary), an empty card becomes a **play-card**. The cue points are stored in the iXML chunk of the file and will only be removed if you erase the play-card; to do so, [jog] to 00:00 and press [gold].

To **hide** a play-card without erasing its cues, press [shift] [gold]. Tagged with a '*' character, the card is no longer visible in the BLUE-TEST/BLUE-REC play list, shortening it .

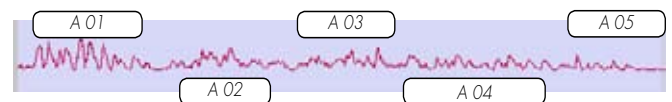

Playfile 'A' from the current project containing five play-cards. Note their chronological placement, suitable for an ADR session.



Playfile 'E' from the archives, containing six play-cards. Note their free and overlapping placement, suitable for playback.

4- With [>] select a play-card and press [ok] to play it from its cue-in. If there is no cue-out in this card or if you want to stop the playback before reaching the cue-out, press [ok]. Press [ok] again to restart from the cue-in. Press [esc] to pause, press [esc] to resume play (there is **NO** delay between 'play' and the audio output).

note1: to get access to the BLUE-PLAY position, press and hold the blue [shift] button while rotating the [MainSelector] to PLAY.



Find a file By default, BROWSE opens access to the *Internal HDD* and the *Current Project* files; to reach files located elsewhere, first select 'Ext.HDD' in SESSION.03, then a project in SESSION.01.

Select a Day by [jog] & [ok], the last take's filetag is displayed; search other filetags by [jog] and [ok]. The displayed 'MB' is the size of *only one* of the tracks of the group.

Edit metadata Scene, take, take-type, comments, track-names and tape-ref can be edited through [shift] [silver], exactly like in PPR (p.20). An individual file can be *trashed*, its .wav extension becomes .rip (latin: *requiescat in pace*); it disappears from the backup list but remains in the day folder from where it can be individually or batch revived from BROWSE (or by computer), changing .rip back to .wav.

BLUE BROWSE

Create 'Play-files'

'Rec&Play' p.48

For Rec&Play to play a file, it must have been indexed as a *Play-file* in BLUE-BRWVS. To get access to BLUE-BRWVS, press and hold the blue [shift] button while rotating the [MainSelector] to BROWSE. Only files located in the Current project folders or Archive folders can be indexed.

• **Current project folders**

A B indexes (see opposite column) are applicable to the current project/current day folder. C D E F indexes are applicable to the current project/any day folders.

• **Archive folders**

G H I J K L indexes are applicable to one of the Archive folders. An Archive folder is a 'One drive, one title, one work-day' folder containing music, songs, wild tracks Play-files, whatever their internal date and time of origination.

To be Cantar playable, audio files must contain iXML v1.50a headers. To 'Cantarize' WAV files coming from any digital recorder, read the Majax imanual page 4.

note1: to convert 44.1kHz MP3 or FLAC into 48kHz WAV files, use 'Sound Converter' <http://www.dekorte.com/projects/shareware/SoundConverter/>.

note2: to update iXML headers recorded in a pre v2.11 Cantar, clone it under an RPA In-Grid (p.28) or use Majax.

Live or clone?

In BLUE-BRWVS.21 'TC mode',

• **'Live'** gives access to all available Play-files. The recording session uses the date, time and metadata of the live action.

Current folders	BLUE-BRWS 01 Drive Internal	Drive set in SESSION (not modifiable)	Archive folder	BLUE-BRWS 12 Arch Drive < External
	BLUE-BRWS 02 Project Shadows	Project set in SESSION (not modifiable)		BLUE-BRWS 13 Arch Pject < NeuArchv
	BLUE-BRWS 03 (AB)folder 2008-03-14	Current folder date (not modifiable)		BLUE-BRWS 14 Arch folder< 2000-01-01
	BLUE-BRWS 04 Index A < SE1234 ok	Select a file in above folder [ok] gives it the A index		BLUE-BRWS 15 Index G < SE1234 ok
	BLUE-BRWS 05 Index B < SE1205 ok	Select a file in above folder [ok] gives it the B index		BLUE-BRWS 16 Index H SE1205 ok
	BLUE-BRWS 06 (CD)folder < 2008-01-31	Select a folder date from the project		BLUE-BRWS 17 Index I < SE1206 ok
	BLUE-BRWS 07 Index C < -----	Select a file in above folder [ok] gives it the C index		BLUE-BRWS 18 Index J < SE1104 n.a.
	BLUE-BRWS 08 Index D < SE1104 ok	Select a file from the folder [ok] gives it the D index		BLUE-BRWS 19 Index K < ----- n.a
	BLUE-BRWS 09 (EF)folder < 2007-12-24	Select a folder date from the project		BLUE-BRWS 20 Index L < SE0980 ok
	BLUE-BRWS 10 Index E < SE0987 ok	Select a file in above folder [ok] gives it the E index		BLUE-BRWS 21 TC mode < Clone (D)
	BLUE-BRWS 11 Index F < SE0980 ok	Select a file in the folder [ok] gives it the F index		BLUE-BRWS 22 AES Loop < Internal

• **Clone (A)** gives access to one Play-file; the recording will use the date, time and metadata of the selected file.

note: Cantar left on STOP, the HDD goes to sleep after a time interval set in TECHSET.16. Going to REC, the pre-record buffer compensates for the disk spin-up, but going directly to BLUE-BROWSE causes Cantar to display 'asleep, no disk', and apply a 'hide' tag to all your unseen play-files! To avoid this mishap, first go to TEST, wait for the 'three-platter' icon to show up, then go to BLUE-BRWVS.



MainSelector East positions

The MainSelector, easy to manipulate even with heavy winter gloves, gives direct access to all essential functions.

The OPERAND positions establish Cantar's operating parameters with no deep diving into sub-menus.

BACKUP	archiving audio files.	1h
SESSION	projects, disks and Sound-Report.	2h
TECHSET	day-in day-out use.	3h
AUDIO/TC	audio parameters/TC management	4h
IN-GRIDS	inputs to tracks routing	5h
OUT-MAPS	outputs to monitors routing	6h

MainSelector buttons

Routings: [black] creates, [gold] removes links.

Rectangular screen rows

Operands are displayed in a way which always indicates their path-tree. Parameters' labels and values are browsed by [[jog] and/or [>] [<] arrows.



- Top row : **Operand, Parameter #**
- Middle row : **Parameter Label**
- Bottom row : **Parameter Value**

ROUTING	p.27	01 In-Grids	02 Out-Maps
AUDIO/TC	p.31	08 Balance fader lock	16 LTC gen. output
01 Sample rate		09 Mic fader links	17 LTC User-bits
02 Bit-depth		10 Line fader links	18 Rec-Run TC init
03 Ref. tone selection		11 Sc&Take template	19 Operator TC init
04 Talkback mic routing		12 AutoSlate channel	20 Digi 1-8 Out
05 PlayOut mute		13 Record by LTC	21 CantaRem com
06 Mixer gain max		14 TC source	22-29 CantaRem-1 assign
07 Pre-record duration		15 LTC rate	30-37 CantaRem-2 assign
TECHSET	p.33	08 Clip detection beep	17 Serial Com. port
01 Disk (un)mount		09 Lack of ext. clock beep	18 Factory Reset
02 Digi in/out AES power		10/11 Beep routing/level	19 Max File Size
03/04 Save/Load Setup		12 Meter speed	20 Temperature Control
05 Backlight		13 Peak hold duration	21/22 System Time/Date
06 View Fader dB		14/15 BatL/BatR alert	23/24 Equipmt IDs/License key
07 Record beeps		16 HDD Power Down	25/26 Software version/Load
SESSION	p.36	04 HDD & DVD format	07-13 Sound-Report headers
01/02 Select/Create Project		05 Scan disk	14 Column layout selection
03 HDD in Use		06 Erase Day	15-29 A-Columns 02 to 16
BACKUP	p.39	04/05 T1-Tx T7T8 treatment	09/10 File name/Media label
01 Save mode		06 Media type	11/12 Snap/Idle Sound-Report
02 Day to copy		07 Burn and check	13 Erase stored poly files
03 Track selection		08 Files to copy	14 Run Backup

The Cantar eight monophonic iso tracks are separated into two groups: T1-T6 on the circular screens, and T7T8 on the rectangular one.

Create T1 – T6 In-Grids

Rotate the [MainSelector] to five o'clock.

note: to avoid spurious activation of PLAY and BROWSE while going to ROUTINGS, the triggering of these two functions is slightly delayed.

T1-T6 can receive any one of the inputs (mic1-5, line1-4, and digi1-6).

Fifteen In-Grid configurations are stored in three groups: A1-A5, B1-B5, C1-C5 (these IDs are displayed on the central screen).

note: To learn the process, create an In-Grid from scratch: erase an existing one by pressing the [gold] button while [jog]ing through the three circular screens.

Example:

Select the ID to be modified/created, a blinking cursor awaits your orders near the '*' on the left circular screen.

To route mic1 to T1, [jog] five positions up and put the blinking cursor facing the mic '1' segment then press the [black] button to accept it; to route line1 to T5, [jog] the cursor through T2, T3, and T4 until you land on T5 (odd tracks are on the outer circle, even tracks on the inner circle). Go to the position opposite line1, accept with the [black] button (clear with the [gold] button).

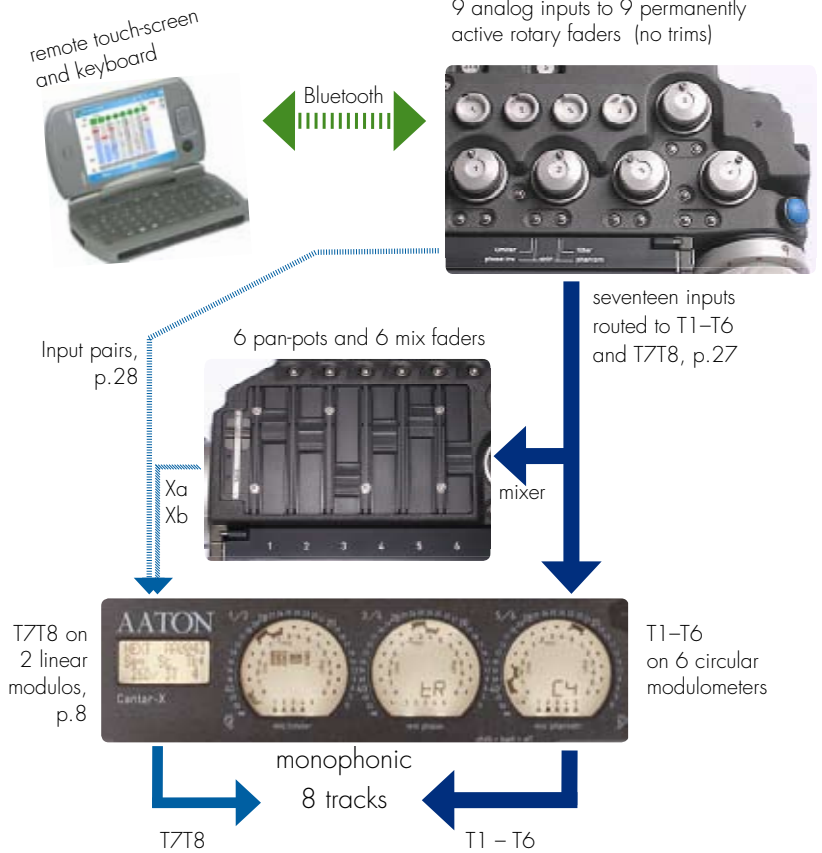
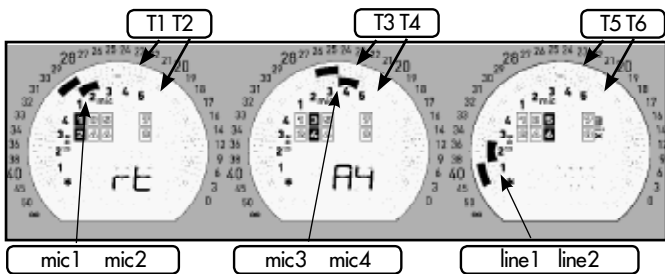

M/S Declaration

If two tracks carry an M/S pair entered on say mic3 and mic4, use the [black] button to activate the 'm-s' icon attached to these two tracks while passing over it. Being 'm-s' declared, these files are monitored as L/R stereo tracks in the outputs and the mix (see Pan-pots, p.17). Aaton Majax (p.56) can decode and replace M/S pairs with L/R pairs for editing machines which can't decode M/S stereo. The suffix of the files carrying M/S tracks carry a hyphen '-' instead of an underscore '_'. Titan3 (p.56), the auto-conforming tool, must carry the cantar.tsc file to handle these hyphen flagged suffixes.





Create T7T8 In-Grids

without Cantarem

Rotate the [MainSelector] to five o'clock. Originally devoted

IN-GRID	#12
T7	T8
m5	Xb+ <

to recording the mixer's output, the T7T8 In-Grids continue to be handled separately from T1-T6 and are displayed on the rectangular screen.

Pressing the [ok] button causes the [jog] to scroll through forty five In-Grid pairs (see table below).

- **No No** (01): T7T8 are disarmed to save disk space.
- **Xa Xb** (02): the T1 – T6 mixer outputs are sent to T7T8; a 'mix' icon appears in the left circular screen.
- **In & Xb** (03): a mic, line or digi-in (e.g. boom) goes to T7, and the mix of T1 – T6 auro-panned to Xb goes to T8.
- **In & Xb+** (04): the '+' sign shows that T7 is inserted at its nominal level into the Xb dynamically controlled mono-mix.
- **In pair** (37): a mic, line or digi pair goes to T7T8.
- **digi7 mic5** (45): tailored for the last track recording of an eight-track 'Re-recording' session (see **RR8** below).

01 no no	13 11 Xb	25 d3 Xb	37 m1 m2
02 Xa Xb	14 11 Xb+	26 d3 Xb+	38 m3 m4
03 m1 Xb	15 12 Xb	27 d4 Xb	39 11 12
04 m1 Xb+	16 12 Xb+	28 d4 Xb+	40 13 14
05 m2 Xb	17 13 Xb	29 d5 Xb	41 d1 d2
06 m2 Xb+	18 13 Xb+	30 d5 Xb+	42 d3 d4
07 m3 Xb	19 14 Xb	31 d6 Xb	43 d5 d6
08 m3 Xb+	20 14 Xb+	32 d6 Xb+	44 d7 d8
09 m4 Xb	21 d1 Xb	33 d7 Xb	45 d7 m5
10 m4 Xb+	22 d1 Xb+	34 d7 Xb+	
11 m5 Xb	23 d2 Xb	35 d8 Xb	
12 m5 Xb+	24 d2 Xb+	36 d8 Xb+	

T7T8 In-Grid table

The T7T8 signal levels are displayed on the rectangular screen bargraphs and on the right circular screen by pressing the [eye] button.

with Cantarem

Thanks to the eight sliders of Cantarem it becomes possible to modulate the T7 and T8 contribution to a mix.

- Select an 'In & Xb' setting (e.g. 03, 05, ...35) above, and devote the Cantarem slider 7 to this input: you record it on T7 and the dynamic mix of T1-T7 (Xb) on T8.
- Select an 'In pair' (e.g. 37, ...44) above, and devote the Cantarem sliders 7 and 8 to this pair, you record them on T7 and T8, and send the dynamic mix of T1-T8 (no longer to Xb) to the Phones, Line-out, Digi-out or Foldback.

note: the panpot of T7 or T8, done by pressing the Cantarem solo button, is displayed on the rectangular screen.

M/S Declaration

T7T8 can't be 'm-s' declared.

AES power

As soon as an AES digi-in is selected in the routings, the digi 1-6 input icons start flashing to remind you to turn the AES power 'ON'. AES converters consume 110mA at 48kHz and 200mA at 96kHz; if they are not in use it is wise to turn them 'OFF' in TECHSET.02 'Digi power'. The AES converters translate any incoming AES sample rate, e.g. 44.1kHz, to Cantar's selected sampling rate, e.g. 48000Hz.

Sixteen Tracks

needs two Cantar-X2s

To impose the same sampling rate and phase, and get a sixteen-track machine, enter a **Wordclock** signal on the SubD 15 Pin-4, and select a 'WC' prefixed sampling rate in AUDIO/TC.01 'Sample Rate'. If you select the wrong sampling rate, 'Wordclock SampleRate mismatch' is displayed on the rectangular screen. If the Wordclock reference is missing, 'Wordclock input missing' is displayed.

Rec&Play In-Grids

see Rec&Play, p.49

Here is a list of T1-T6 & T7T8 In-Grids for most Rec&Play sessions:

- to perform a 'Remix': select **RPM** = B2 (see (*) below) & O2 (see opposite table).
- to perform an 'Archive file update': **RPA** = B2* & 44.
- to perform an 'eight-track Re-recording': **RR1** = A1* & O1, **RR2** = A2* & O1, **RR3** = A3* & O1, **RR4** = A4* & O1, **RR5** = A5* & O1, **RR6** = B1* & O1, **RR7** = B2* & 11, **RR8** = B2* & 45.

*T1-T6 setups (p.27)

A1 (mic5/T1), **A2** (mic5/T2, digi1/T1), **A3** (mic5/T3, digi1/T1, digi2/T2), **A4** (mic5/T4, digi1/T1, digi2/T2, digi3/T3), **A5** (mic5/T5, digi1/T1, digi2/T2, digi3/T3, digi4/T4), **B1** (mic5/T6, digi1/T1, digi2/T2, digi3/T3, digi4/T4, digi5/T5), **B2** (digi1/T1 digi2/T2, digi3/T3, digi4/T4, digi5/T5, digi6/T6).

With 'TECHSET.03 (p.33), save these A1, ...B2 setups, and name them 'Clone1'. Loading them for your next cloning session will be a great time saver.



The 3 Screen paradigm

Here is where the Cantar screen lay-out is at its best: signals going to the left ear are displayed on the left, signals to be listened to in mono are displayed on the middle, and those going to the right ear are displayed on the right. The middle screen does not represent a wired output but the 'mono' effect resulting from the routing to both the left and right ears.

Create Out-Maps

Rotate the [MainSelector] to six o'clock.

note: to avoid the activation of PLAY and BROWSE while going to ROUTINGS, the triggering of these two functions is slightly delayed.

Grouped in banks accessible from the black [monitor] crown,

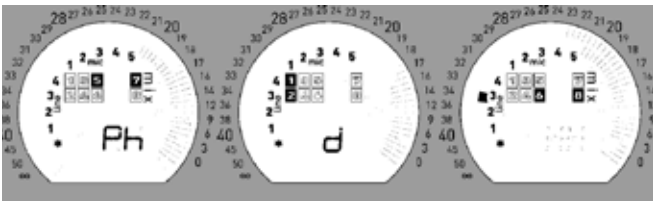

'Ph d' • T5 T7 left, T1 T2 both ears (mono listening), T6 T8 right • miXa left, miXb and line3 right.

nine *OutMaps* are shared by digi-out **Do**, foldback **Fb** and line-out **Lo**, and eleven are devoted to the phones **Ph**.

The eight tracks, the miXa and miXb outputs, the nine analog and the six digital inputs (recorded or not) are independently routed to the outputs, which are treated in the same manner since they all carry a left and a right channel.

The 'Ph d' example below is applicable to any output.

• Tracks to outputs

Rotate the [monitor] crown to **Ph**, the left circular screen displays **Ph**. Rotate the [config] crown to get **d** on the middle circular screen.

left screen: [jog] the black blinking cursor to the T5 square, press the [black] button to 'link' track5 to the left ear (press the [gold] button to 'unlink'), the blinking frequency increases to acknowledge the link (do the same for T7).

middle screen: [jog] the black blinking cursor to T1, press the [black] button to link track 1 to both the left and right ears (same for T2).

right screen: [jog] to T6, press the [black] button to link track6 to the right ear (same for T8).

If you want an 'm-s' recorded track pair (say T5 T6) to be sent as L/R stereo to the **Lo**, **Fb**, **Do** outputs, create an *OutMap* in which T5 goes to the left and T6 to the right, Cantar will *automatically* decode these M/S tracks as L/R. This applies to the T1T2 and T3T4 pairs too, alone or together.

• Inputs to outputs

Any input (mic1 – 5, line1 – 4, digi1 – 6), can be sent to the outputs. While the blinking black cursor jogs on the inner ring of the circular screen, it points out the input to be possibly routed to the left/both/right ears, 'link' the desired input by pressing the [black] button.

Out-Map banks

Rotate the black [monitor] crown over the **Do**, **Fb**, **Lo**, **Ph** and **So** positions, then rotate the silver [config] crown to display the *OutMaps* of each.

Do Digi-out

Nine user created **R** to **Z** maps and **XX** (miXa/miXb). The two digital-out channels go to the AES-7&8 ports (p.57).

Fb Foldback

Nine user created **R** to **Z** maps and **XX** (miXa/miXb). The two foldback channels go to a Mini-XLR3.

(*Foldback level*, p.18)

Lo Line-out

Nine user created **R** to **Z** maps and **XX** (miXa/miXb). The two line-out channels go to an XLR5.

(*Line-out level*, p.18)

Ph Phones

Fifteen user created **A** to **Q** maps and **XX** (miXa/miXb). The two phones channels go to a 1/4" jack (p.57).

(*Headphone level*, p.18)

So Solos

Solos connect the headphones to each of Cantar's ins and outs: **M1... M5**, **L1... L4**, **T1... T8**, and to the mixer generated signals: **XA** (miXa center), **XB** (miXb center), **XC** (miXa+miXb center), **XX** (miXa/miXb left-right).

The modulus of miXa and miXb appear on the rectangular screen.



Digi 1–8 out (AES 1–8)

The use of the AES outputs is recommended to send audio signals to the external world: totally transparent, no interference prone cables.

Connect them to video cameras featuring AES inputs (such as the Sony HD-Cam F900-SR), or to an SDI camera equipped with a miniature AES-to-Analog converter.

The eight AES outputs are separated into two groups:

- *the Digi - out 1 2, 3 4, 5 6 pairs* transmit
tracks 1 – 6
or
mic1–5 & line1

The 'mic1–5 & line1' option lets you use Cantar's high quality preamplifiers/limiters to send audio signals to an external mixer and re-enter them through the digi 1 to digi 6 inputs to record them.

- *the Digi - out 7 8 pair* transmits either
tracks 7 & 8
or
a DO selected Out-Map, including the stereo mix.

See AUDIO/TC.19 'Digi1–8 Out', p.32.

So is close to the **Ph** position for a good reason: the last activated solo map is kept in memory and immediately sent to the phones when toggling between **Ph** and **So** (see an application below).

The **So** position monitors the dynamic mix of the PLAYed file (like in TEST or REC). As an operational PLAY tip, you can instantly compare your recorded mixdown '**Ph A: T7T8 center**' and '**So: XC**' by toggling between **Ph** and **So**, this is used to 'evaluate' the necessity of a remix either with Cantar Rec&Play or later.

As an alternative to the **So** position, the *mic inputs* can be instantly solo-ed by pressing their [so-fil-tom] buttons, and the *tracks* by pressing their [track-solo] buttons.

note1: the **XX** selection lets you output miXa and miXb whether or not they are recorded on T7T8.

note2: **Ph Q** adds miXa and miXb to the operator's selected Out-Map, e.g. the L/R decoded miXa/miXb of M/S pairs recorded on T1T2, T3T4, T5T6 can be added to the T7T8 Out-Map.

AES power reminder

As soon as you select an Out-Map with digi-out, the track icons start flashing in the circular screens to remind you to turn the AES interface 'ON'. This interface consumes 110mA at 48kHz and 200mA at 96kHz, if it is not in use, turn it 'OFF' in TECHSET.02 'Digi Power'.



- 01 Sample rate
- 02 Bit-depth
- 03 Ref. tone select
- 04 Talkback mic routing
- 05 PlayOut mute
- 06 Mixer gain max
- 07 Pre-record duration
- 08 Balance fader lock
- 09 Mic fader links
- 10 Line fader links
- 11 Sc&Take template
- 12 AutoSlate channel
- 13 Record by LTC
- 14 TC source
- 15 LTC rate
- 16 LTC gen. output
- 17 LTC User-bits
- 18 Rec-Run TC init
- 19 Operator TC init
- 20 Digi 1-8 Out
- 21 CantaRem com
- 22-29 CantaRem-1 assign
- 30-37 CantaRem-2 assign

01 Sample Rate

44100 47952 48000 48048
88200 95904 96000 96096

For CantarX2 'wordclock slaving', select the WC prefixed values, e.g. WC 48000, which are the same as the non-WC rates (see *Sixteen tracks*, p.28).

02 Bit Depth

16-bit 24-bit

Select 16-bit if you know the final mix will be done in 16-bits. Dither or truncate to 16-bit from native 24-bit tracks is available when backing-up the mixdown, see BACKUP.05 'MxDwn Trmt', p.40.

03 Tone Level

See *Ref. Tone generator*, p.22.

-20dBFS -18dBFS Off

04 TalkbackMic

Off Line-out Foldback Lo+Fb

On top of these routing choices, left/right selection is made with the [MainSelector] black button.

in TEST or PPR: [black] continuous: talkback mic goes to left channel(s), e.g. the boom operator.

[black] short, then [black] continuous: mic goes to the right channel(s), e.g. the director and script supervisor.

[shift] [black] continuous, mic goes to both left and right, for talking to both boom operator and director.

in REC: [shift] [black] continuous, mic goes to all tracks.

05 PlayOutMute

No Mute Mute Line Mute Fldbk Mute Lo+Fb

This lets you mute the outputs to Video Village, while play-

ing the preceding take for the director. The [routing] button instantly defeats the PlayOut Mute.

06 MixGain Max

0dB +6dB

Mixer's faders top position gain. In +6dB mode, the 0dB mark is the indentation in the linear faders' guide rails.

07 PreRec Dur

1 to 35 sec.

Pre-record buffer duration. Up to 35 seconds @ 8 tracks, 24-bit, 48kHz. (17 seconds @ 96kHz).

08 BalanceLock

Unlocked Locked

Slaved fader status, see *Mic links*, p.17.

09 Mic Links

1>2 & 3>4 1>2.3 1>2.3.4 1>2.3.4.5 1>2 & 3>4.5

The 'sleeping' mic-link presets are activated with the button between the faders M1 & M2, and M3 & M4. The master is to the left, the slaves control the ±12dBu balance.

10 Line Links

Off 1>2 & 3>4 1>2 3>4 1>2.3 1>2.3.4

Contrary to the sleeping mic-links, line-links are immediately activated from the selection menu. Slaved faders have no

balance function, they get their gain value from the master. The 1>2.3 choice is to be used for the Soundfield ST350 line level outputs (see *Soundfield B-Format*, p.44).

11 ScTk Templt

nnnA/nnA.nn CCCCCCCC.CC

The nnnA/nnA.nn template fits the mostly used Sequence/Scene system. The 'all C' template is totally open, giving the operator maximum flexibility (see *Scene and Take*, p.19).

12 Slate Chanl

See *AutoSlate*, p.23

Off mic 1... mic 5

line 1... line 4 track 1... track 8 (CantarX2 only) .

AUDIO/TC 10
Line links
1>2 & 3>4



13 Rec by LTC

see Remote Control, p.21

Inactive Active

In PPR, LTC input running, Cantar checks the TC coherence for three seconds then goes to record. While checking the validity of the LTC signal, the audio is kept in a buffer, the audio file begins right on the running LTC. If the LTC input disappears, recording is maintained, no risk of interruption caused by radio transmission drop-outs. Only a frozen LTC input can stop the recording.

14 TC Source

Int.Clock Ext.Clock Int.Fudge Ext. Fudge

On 'Internal Clock', Cantar is *the* master-clock.
 On 'External Clock', Cantar is slaved to another timecode source (p.14).
 On 'Fudge', the time stamped on the recorded files compensates for a flaw of some HD cameras*. This 'fudge' (which places the correction on the recordist's shoulders) is not saved in Cantar preferences. 'TC Source' toggles back to 'Int' or 'Ext' clock each time power is switched off. As a reminder, the Atc, Etc or Stc flag becomes Atc+, Etc+ or Stc+. To avoid the TC difference which would jeopardize the final mix autoconformation, iso tracks and backups are both 'fudged' by the same 60ms offset.

* Sony HD cameras stamp their files without taking into account the latency of the internal image treatment, e.g. an image shot at 12h05m01s 00ms is stamped as 12h05m01s+60ms.

15 LTC Rate

24FPS 25FPS 29.97DF 30FPS 23.98NDF 29.97NDF

In the NonDropFrame -0.1% slow-second world, an -A, -B or -C time stamping method must be selected (see p.15).

16 LTC Gen Out

On Off

In PLAY, the LTC-out carries the TC and fps of the played files, not the project's ones. It can control a chasing VTR while Rec&Play is used for 'Remix' and 'ADR type2'.

17 LTC Ubits

Iso Date (Filetag TapeRef Freeform MDY Date are not yet available)

The Iso Date is 'Year Month Day'.

18 RecRun Init

01h00m00s

The Record-Run clock jumps one hour at each rectangular screen bottom line opening.

'Rtc' (Record-Run) is activated for the recording session and stays there until another TC Source is selected; in this case the clock goes back to its default Free-Run mode.

19 OperTc Init

01h00m00s

The operator TC becomes the next recording session reference. 'Otc' is displayed in the rectangular screen. It is disabled as soon as Free-Run TC from an external source jams the internal clock.

20 Digi 1-8 Out

T1-T6 & Do M1-5 L1 & Do

- The Digi 1-6 AES outputs either transmit the T1-T6 recorded iso tracks or the mic 1-5 + line1 signals (p.30).

When in BLUE Rec&Play mode, the Digi 1-6 outputs are internally redirected to the AES-in 1-6, unless in BLUE-BRWS.22, 'AES loop' is set to 'external'.

- The Digi7-8 outputs transmit the Do routed signals (p.30).

21 CantaRemCom

Inactive Active Forced

'Active' makes CantaRem (p.53) control Cantar until its cable is disconnected from the SubD15 ASCII port. 'Forced' allows CantaRem to control the STOP, TEST, PPR and REC functions when the [MainSelector] is physically set to the PPR position.

22 RemFader A1 29 RemFader A8

AUDIO/TC	29
RemFader A8	
line-in 4	

The assignment of the CantaRem RemFaders to the mic and line-in rotary faders, to the mixer linear faders, to the line-out and fold-back levels can be performed from either the CantaRem keys or from the AUDIO/TC 22-29 menus.

30 RemFader B1 37 RemFader B8

Available when two CantaRems are connected.



01 Disk (un)mount	14/15 Bat L/ Bat R alert
02 Digi in/out power	16 HDD Power Down
03/04 Save/ Load Setup	17 Serial Com. port
05 Backlight	18 Factory Reset
06 View Fader dB	19 Max File Size
07 Record beeps	20 Temperature Control
08 Clip detection beep	21/22 System Time/Date
09 Lack of ext. clock beep	23 Equipment IDs
10/11 Beep routing/level	24 License key
12 Meter ballistics	25 Software version info
13 Peak hold duration	26 Software install

01 Disk Status

Unmount Mount

Two CPUs can't simultaneously control Cantar's drives.

Unmounting the internal HDD and DVD-RAM drives puts them out of the control of Cantar's CPU while keeping them powered. A FireWire connected PC or Mac can then see them as standard devices on which to edit the audio files and transfer software updates.

While using a Mac laptop, you must install 'WriteUDF' to be able to modify the metadata on a DVD-RAM disk in the Cantar burner (see *Majax*, p.56).

WARNING: before disconnecting the FireWire cable, FIRST, eliminate the 'disc' icon from the PC or Mac desktop, THEN disconnect the cable. Ignoring this rule will trigger a warning message, but it will be too late; the audio files may already be corrupted.

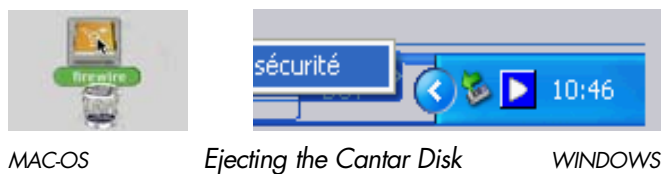

MACOS Ejecting the Cantar Disk WINDOWS

02 Digi Power

Off On

'Off' saves 110mA@48kHz, 200mA@96kHz. The digi 1 to digi 6 icons of the circular screens blink as a reminder to turn 'On' the sample rate converters that have been routed but not powered up.

03 Save Setup

all user settings

No Yes

All of Cantar's physical settings (IN-GRIDS, OUT-MAPS, TECHSET and AUDIO/TC parameters, mic filters, etc.) can be saved in up to twenty User's Setups xml files on the external HDD (or the internal HDD if there is no external drive connected). To ensure a unique name for each User's Setup, it is named by the last recorded filetag, e.g. AB1234+A.xml. Since you can use them in another Cantar, copy your favorite User's Setups onto a laptop before returning a rented machine, re-importing them for your next assignment will be a great timesaver; just think about the time you spent setting the RR1-RR8 *re-recording p.28 In-Grids!*

Using an internet browser, and provided you keep the .xml extension, you can replace the eight char. AB1234+A.xml filetag name with a descriptive one, e.g. Custom01.xml or Kitchen4.xml.

note: in case of an operational problem, perform a 'Save Setup', attach it to your mail to cantar-support@aaton.com explaining the problem. This will help Aaton engineers provide you with a solution.

04 Load Setup

No Yes

Opening 'Load Setup' makes Cantar look for .xml suffixed files in the external and internal HDDs. Select the setup to load, e.g. Custom01, [ok]. Press [shift] to reboot.

05 Backlight

0% to 100%

In bright sunlight, save power by turning 'OFF' the backlight. To insure visibility whatever the startup lighting environment, the rectangular screen doesn't go down to 0%, this offset is maintained throughout the adjustment range.

06 Display dB

On Off

While adjusting a fader, its dBFS value is displayed with the other faders found in the same mic, line or mixer bank.

**07 Record Beep**

None Start only Start+Stop

Single beep on 'start', double beep on 'stop'. The double beep is useful to warn you when the video camera stops, while recording in Remote Roll by LTC.

It is also a means for your boom to know you are still recording the background noise after the director's 'CUT!'.

08 Clip Detect

Beep On Beep Off

09 No Ext TC

Beep On Beep Off

Activated if the external clock is missing while in External Clock mode. The beep is automatically disabled while recording 'w' (wild track) takes.

10 Beep Route

Phones, Ph+Line-out, Ph+Foldback, Ph+Lo+Fb

11 Beep Level

0dB to -60dB

12 Meter Speed

1 Fast 2 3 Med 4 5 Slow

Select **5 Slow** in low temperature conditions.

13 Peak Hold*peak hold duration*

0.5 sec to 5 sec

14 Bat L Alert 15 Bat R Alert

10.8 Volt to 15.0 Volt

Each battery socket can be set to its own alert level, automatic switch-over occurs 300mV below this level. Once a battery drops below its alert level, a two beep alarm is sent to the headphones. Aaton Li-Ion batteries are 16.5V 'no load', and deliver 14.8V under load, it is safe to set the alert @**14.2V** (13.9V switch-over) to be sure not to get into the steep power end zone. NiMH battery alert should be set @**10.8V** (10.5V switch-over).

16 HDD Pwr Dwn

Afr 1min to Afr 255min

In STOP, the HDD eats half of Cantar's power, it is wise to put it to sleep. While in sleep, the 'three-platter' icon blinks.

Go to TEST to wake-up the HDD; it will be up to speed within three to ten seconds, the pre-record buffer hides this speed ramp-up. Cantar's cold start from an un-powered machine to recording is a blazing two to three seconds.

note: during IdleCopy the HDD doesn't go to sleep.

17 Serial Com

Factory Bluetooth

'Factory' for maintenance techs, 'Bluetooth' for PDAs only.

note: on Cantar-X2, the Ethernet interface is permanently active.

18 FactoryReset

No Yes

All menu parameters are reset to their factory default.

19 MaxFileSize

250MB 690MB 2GB 4GB

The current file is closed and the next one opened when the set limit is reached, without losing a single sample. Four lengths are available: 250MB (to make 8 polyphonic tracks @ 24-bit/48kHz fit within the 2GB basic FAT32 limit, 690MB (for 700MB CD-Rs), 2GB, 4GB (max file size). You also have the choice of triggering the jump by swiftly changing from REC to PPR and back to REC.

20 Show Temp

Temperature is displayed on this screen until you exit this item.

• Lcd+02

The heater option displays the circular LCD's temperature that the heaters control. It takes about fifteen minutes to reach the +2°C to +4°C equilibrium in a -15°C environment. To save power, Cantar should be in a carrying bag, preferably with insulation. Also, it is recommended that you set TECHSET.12 'Meter Speed' to '5 Slow'.

• Hdd-05

This is the internal temperature. Below -5°C, it is recommended to replace the standard Travelstar HDD with a low temperature disk, such as the 80GB Hitachi Endurastar, or a Solid State Drive (see p.43).



21 System Time

00h32m24s

Enter the time from your watch (\pm five minutes), especially if you just started working in a new time zone. The system's date (which relies upon hour and minutes around midnight) is used to sort the workdays, it should not be confused with the timecode which is used for syncing picture and audio.

22 System Date

2004y04m22d

The system date is used to create the folder name (YYYYMMDD) containing the files for that workday. Note that the workday folder can contain hours past midnight, if the recording session is not interrupted (e.g. turning 'OFF' the Cantar). The workday is also used to fill the default MMDD name of the TapeRef field.

23 Hardwr IDs

SN 0520, MoBo CM5 (CM3), Preamp SL1 (SL0),
Ether ET1 (none), Conv AD5 (AD3)

Cantar's Serial number, Motherboard, Preamps, Ethernet interface, A/D converter versions. Keep these labels in mind when contacting Aaton's technicians.

24 License Key

Unlimited 24 Days

Protection against unauthorized use: Cantar goes to 'general freeze' after a given number of calendar days. The key can be activated or deactivated by a CMU software key emailed by Aaton. If 'Unlimited' appears, go no further, your Cantar is set to work forever.

25 Softwr Ver.

v2.11 v2.15

The current software copy is stored in Cantar's EEPROM, no need to keep it in the HDD. You should not keep more than three versions; erase the old ones. To install a new version, see below.

26 Softwr Load (new software installation)

No Yes

As a registered Cantar owner, get the latest version from <http://soft.aaton.com/swcantar/>. Put the file (can-xxx.flb) on your Mac/PC desktop.

Instructions

please read completely before proceeding

1 Connect a cable to the Cantar FireWire socket while it is *unpowered* (p.5).

2 To avoid any power interruption during the following operations, **ACTIVATE BOTH ONBOARD FULLY CHARGED BATTERIES** by simultaneously pressing the [battL] and [battR] buttons for three seconds. A loss of power will prevent Bios re-installation; 'ERROR Num 1B XILINX' will be displayed, meaning 'Return Cantar to the factory'.

3 *First* unmount the HDD in TECHSET.01 'Disk (un)mount' *then* connect the FireWire cable to the computer. The Cantar HDD icon will be displayed on the computer's screen.

4 Copy the can-xxx.flb file to the root of the Cantar HDD. **NEVER** install a version lower than 1.78.

5 Dump the Cantar HDD icon out of the computer, then disconnect the FireWire cable (see the warning in TECHSET.01 'Disk (un)mount', p.33).

6 Set TECHSET.01 to 'Mount' the internal HDD; this is done when the 'three-platter' icon is no longer blinking.

7 Set TECHSET.26 'Softwr Load' to 'Yes'.

8 Select the desired version, [ok]. For safety, all controls are disabled during this one minute operation. **Do NOT touch** anything until 'Success Press Shift' is displayed.

9 Press [shift] to finish the installation and shut down Cantar. Set the [MainSelector] to STOP, and restart.

10 Cantar is protected from the installation of corrupted software. Go to TECHSET.25 'Softwr Ver.'; if the new version doesn't show up, that's all the message you will get; something went wrong, re-download the software from the Aaton site and re-install.

Software Installation from an external disk

Connect a go-between disk to your laptop and copy can-xxx.flb to the disk root. Unplug it and hook it up to the Cantar FireWire port. *Activate both onboard fully charged batteries* by simultaneously pressing the [battL] and [battR] buttons, then follow steps **7** through **10** above. This method works because Cantar, while installing software, first looks for .flb files in the root of the external disk.



01 Select Project Name	07 Full Title ...
02 Create New Project	13 Picture Format
03 HDD in Use	14 Column layout
04 Disk Formatting	15 A-Column 02 ...
05 Scan Disk	29 A-Column 16
06 Erase Day	

01 ProjectName

AACANTAR EDENWEST

Max. eight characters. If the disk has been erased by the rental facility, 'No Project' is displayed. Going directly to REC creates a default AACANTAR project folder.

02 New Project

SHADOWS2

The bottom line of the rectangular screen displays the projects already stored. Press [ok] to create a NEW project (8 alpha/numeric char.), a triangle points at the character to be set. [jog] to select a character then press [>] or [<] to go to the next letter. Project name entered, press [ok] then go to REC to write a short validation file.

03 HDD in Use

Int.HDD Ext.HDD Int+Ext.HDD

Audio files can be recorded on internal or external HDD or both simultaneously. If Int+Ext.HDD is selected, recording at 24bit 96kHz is limited to six tracks.

When listening to recorded files, only the internal drive plays. To listen to files on the external drive, switch to 'Ext. HDD' and don't forget to switch back afterward.

note: the message panel displays the lowest remaining disk space in Mega Bytes.

FAQ: I select SESSION.03 'Int+Ext.HDD', I connect an external HDD and wait for its activity LED to turn green, but it doesn't. Wait for the 'three-platter' icon to stop blinking in the middle circular screen, then go to 'Int+Ext.HDD'. If Cantar still doesn't see the disk, most probably it is not FAT32 'One Primary Partition' formatted. (see below).

04 Disk Format

HDD/SSD/CF DVD-RAM

Almost identical operations for hard drives and DVD-RAM optical medias.

HDD/SSD/CF formatting

Cantar HDD/SSD/CF do not use a proprietary format, they are FAT32 'One Primary Partition' formatted, directly accessible by both Mac and PC.

Internal Open the disk compartment and unscrew the disk carrying shuttle. Following the instructions below, connect it to Cantar through a FireWire cable as an external device. This is protection from accidental erasure by idle fingers.

External FireWire connected, Cantar formats it up to 127GB which is Microsoft's commercial limit for FAT32. To format a larger disk, see *Tutorial 1, Disks* (p.43).

Instructions

(please read completely before proceeding)

1 With no external 'Device' plugged-in, go to SESSION.04 'Disk Format', [ok], 'Shift+Gold' is displayed.

2 Press and hold the [shift] [gold] buttons while connecting the external 'Device' to Cantar; continue to press them until 'Formatting' is displayed on the rectangular screen, then release both.

To avoid mishaps, plug the FireWire cable into the rear socket while Cantar is not powered; hold it with the retaining screw (p.5). Later – while the [shift] [gold] buttons are pressed –, connect the other end of the cable to the 'Device' (for CF cards, see note2).

3 'Done' is displayed when formatting is finished. A 'three-platter' icon appears on the middle circular screen. Go to STOP.

note1: most HDDs are consumer products and their life span ranges from one to three years. Formatting a disk doesn't protect you from dead clusters. Regularly **scan** your drives, see below SESSION.05 'Scan HDD'. Even if there is only **one** defective cluster, **immediately discard the drive**.

note2: you can leave the CF card converter permanently connected and introduce the card while the [shift] [gold] buttons are pressed.



DVD-RAM formatting (UDF 1.5)

Cantar can record onto FAT32 formatted DVD-RAMs but for Mac/PC interchangeability, it only formats them under UDF 1.5.

Instructions

please read completely before proceeding

1 With Cantar powered, go to SESSION.04 'Disk Format', press [ok], 'Shift+Gold' is displayed.

2 Insert a DVD-RAM in either the external or internal burner, and before the 'one-platter' icon appears, press [shift] [gold] together. Keep them pressed until the 'Formatting' message is displayed on the rectangular screen.

3 'Done' will be displayed when the format has finished. The 'one-platter' icon appears on the right circular screen to indicate the DVD-RAM is ready for use. Go to STOP.

note: To work with a DVD-RAM on a Mac, see p.43. To play it on a DV40/824, contact Aaton.

05 Scan HDD

Int.HDD Ext.HDD

Scanning an 80GB HDD may require two hours to complete. At the end of the scan, the message should be 'No error'. If 'One error' appears, immediately copy all of your files and discard the disk. Remember that a hard jolt can force the disk heads to crash and scratch the surface resulting in one or more dead clusters.

If for some reason you must perform an urgent REC while scanning the internal disk, abort the scan by pressing [esc] for a few seconds until 'aborted' is displayed.

06 Erase Day

No Yes

To reduce disk fragmentation, file erasure is performed on full workday folders only. 'Select Day', [ok]; [jog] to select a day, [ok]; the bottom line displays 'ScanningDay' then the cursor jumps to 'Day Eraser'; [jog] to select 'Int.HDD' or 'Ext.HDD', [ok]; [jog] to 'Yes nnnMB', [ok]. Once the day's files have been erased 'No Files Found' is momentarily displayed, then the bottom line changes to 'No 0.0MB'.

[ok] returns to 'Select Day', [esc] goes back to SESSION.01 'ProjectName' where another project can be selected.

Reminder: when *trashing* an individual file its .wav extension becomes .rip. It is hidden but not erased from the workday folder (p.25).

Sound-Report – Headers

Eight header items – FileType, TapeRef, ToneLevel, Sample rate, Bit-depth, FPS, Date and Media – are automatically filled with the recording parameters, while seven others (see 08 to 14 below) carry operator entered data.

Multiple changes to each header item are allowed per workday. If one header item changes, a new PDF and ALE page is started with this information.

07 (Project)+Full Title

For consistency the 8 character Project name is automatically inserted in the header before the operator entered Full Title. (max: 39 characters). All of the header entries below are automatically recalled when re-opening the project.

note: [shift+esc] clears each of these fields individually.

08 Production (max: 30 chars.)

09 Director (max: 25 chars.)

10 Sound Mixer (max: 25 chars.)

11 Location (max: 25 chars.)

12 Day's Topic (max: 19 chars.)

13 Pic Format (PAL, NTSC, HD1, HD2)

Title: Shooties		Pic Format: PAL		Center # 032		SOUND REPORT # 07028AD								
Prod: AATON		Tape: Jane meets Paul		TC Sp: 24.00		Media: Snap Report								
Director: Adam		Location: Granada		Digit: 48KHz-24 bit		Tape Ref: 0829								
Sound Man: Jonathan				Tone level: -18 dB		Type: Monophonic								
01	08:47:5	1:19	00	11:26:30	00:01:02	Paul	Jane	Ext	stereo	stg2	Wk left	Wk right	4.8MB	20:08:10:00
meeting call														
2	08:47:7	1:19	00	11:27:45	00:01:45	Paul	Jane	Ext	stereo	stg2	Wk left	Wk right	4.8MB	20:07:47:00
meeting call														
3	08:47:9	1:19	00	11:30:45	00:00:04	Paul	Jane	Ext	stereo	stg2	Wk left	Wk right	4.8MB	20:08:47:07
meeting														
4	08:47:9	1:19	00	11:30:55	00:00:04	Paul	Jane	Ext	stereo	stg2	Wk left	Wk right	4.8MB	20:08:47:07
meeting, urban traffic														
5	08:48:0	1:19	00	11:32:35	00:00:22	Paul	Jane	Ext	stereo	stg2	Wk left	Wk right	4.8MB	20:07:20:07
meeting, urban traffic														
6	08:48:1	1:19	00	11:38:00	00:00:28	Paul	Jane	Ext	stereo	stg2	Wk left	Wk right	4.8MB	20:08:12:00
meeting, urban traffic														
7	08:48:2	1:19	00	11:38:00	00:00:28	Paul	Jane	Ext	stereo	stg2	Wk left	Wk right	4.8MB	20:08:12:00
meeting, in the park														
8	08:48:3	1:19	00	11:38:00	00:00:28	Paul	Jane	Ext	stereo	stg2	Wk left	Wk right	4.8MB	20:08:12:00
meeting, in the park														
9	08:48:4	1:19	00	11:40:15	00:00:41	Paul	Jane	Ext	stereo	stg2	Wk left	Wk right	4.8MB	20:08:12:00
meeting, in the park														
10	08:48:5	1:19	00	11:43:30	00:00:44	Paul	Jane	Ext	stereo	stg2	Wk left	Wk right	4.8MB	20:08:12:00
meeting, in the park, children playing														

Built-in easy to read and print PDF report



Sound-Report – Columns

User configurable columns carry the take specific data.

14 Col Layout

Layout-A Layout-B Layout-C

Three custom operator maintained layouts are available, they are stored in Cantar's memory and can be modified by [jog]-ing through the column/field linking positions (see SESSION.15 below). The first letter identifies which layout (A, B or C) the selected column is modifying (e.g., A-Col.12, B-Col.12, C-Col.12).

15 \$-Col.02 to 29 \$-Col.16 (\$=A, B or C)

[INS field] [DEL field] Blank Filetag
 Seq/Scene Take TCStart TCEnd Duration
 TCslateA TCslateB TCslateC Track rank
 Tracks used FileSize User-bits

Column '01' displays the recording order; it is not modifiable. To assign a different field to columns 02 to 16, press [ok] and with [>] [<] select one from the available list (above).

[DEL field] eliminates the field assigned to the selected column and shuffles the fields on the rightside to the left; 'none' is displayed on the last column. If you want to activate a 'none' column press [ok] to change it to 'blank', then select any field for it.

[INS field] inserts an empty placeholder ('blank') that can be filled with a specified field; other fields are pushed to the right... provided there is at least one 'none' column on the far right.

Track rank represents track 1 through track 8.

Sound-Report – Files

PDF (Portable Document Format)

Three independent PDFs are created: 'All' contains all of the 'tpwan' take-types, 'Wild' extracts the 'w' takes, 'Trio' displays the takes carrying one or more Linking-Trios (see p.48).

The PDF files are named using: the calendar date, followed by the take selection **A**, **W** or **T** (All/Wild/Trio) and the file treatment **D**, **N**, **R** or **X** (Direct multi-mono/Native poly/Rotated poly/miX poly), e.g. 081224AR.pdf, 081224TD.pdf. The 'comment' field (max: 200 char.) is used as the take separator. Disarmed tracks carry no track-name. Paper size is unified @ 21x27.2 cm to fit both 'A4' and 'Letter' formats.

note: on some Mac firmware, you must open the PDFs with 'Preview' (Aperçu), since Adobe Reader or Acrobat can't directly print them properly.

CSV* & ALE (Avid Log Exchange)

A CSV tab-delimited table for spreadsheet applications, as well as an ALE list for editing machines are systematically generated with the PDF.

These files are named using: the month and day numbers, followed by the treatment **D**, **N**, **R** or **X**, and the page number, e.g. MMDD_R##.ale. A new page ## is opened each time a new parameter value (fps, sample-rate, etc.) appears in the sound-report header.

note: not yet reading the iXML chunk embedded in the BWF files, Avid MCs only have access to the first 40 characters of the comments stored in the 'aNote' of the BWF descriptor.

* Originally CSV stood for 'Comma Separated Values, they are now, most of the time using tabs instead.

Sound-Report – Generation

For the latest entries of the day to be taken into account, the last report overwrites the former one. It takes a little more than one minute to build a twelve page sound-report.

- Any time

Go to BACKUP.11 'Snap Report', select the **Dir**, **Nat**, **Rot**, **miX** status of your choice. Press [ok] to send the Sound-Report to a YYYYMMDD.AA# folder on the drive(s) in use as selected in SESSION.03.

note: to redo a Sound-Report for a preceding day (e.g. edited with Majax or Cantar), set BACKUP.01 'Save Mode' to 'Backup@Call', then BACKUP.02 'Day to Copy' to (the date), then BACKUP.11 'Snap Report', etc.

- After IdleCopy

Before [eject]-ing the DVD-RAM or removing the external HDD, set BACKUP.12 'Idle Report' to 'Yes'. The Sound-Report is sent to the YYYYMMDD.AA# folder where it carries the same **Dir**, **Nat**, **Rot**, **miX** status as the backup files.

- After Backup@Call

Set BACKUP.14 'Run Backup' to 'Yes'. The Sound-Report is created when the backup is completed, it is sent to the YYYYMMDD.AA# folder where it carries the same **Dir**, **Nat**, **Rot**, **miX** status as the backup files. (# = **D**, **N**, **R** or **X**).



- 01 Save mode
- 02 Day to copy
- 03 Track selection
- 04 T1-TX treatment
- 05 Mixdown treatment
- 06 Media type selection
- 07 Burn and Check
- 08 Files to copy
- 09 File name
- 10 Media label
- 11 Snap Sound-Report
- 12 Idle Sound-Report
- 13 Erase Polys
- 14 Run Backup

01 Save Mode

IdleCopy Backup@Call PolyStore

• IdleCopy

This mode can be activated any time, the earlier in the day, the better. Parameters excluded by an operator's previous choice are flagged as 'N.A.'. When the internal HDD is not occupied by any other task, i.e. in TEST or STOP, Cantar incrementally copies the files of the day onto DVD-RAM (external or internal), CF card or external HDD. By the end of the day most audio files are copied. This is an alternative to the simultaneous recording on both the internal and external HDDs. IdleCopy updates archived files; if you modify the metadata of a take, its copy is erased and re-saved.

To interrupt the process, go to PPR or press [esc] until 'IdleOp Stop' is displayed; the unfinished file copy is erased. The operation will resume upon entering TEST or STOP. Note that a five second delay lets you go to PLAY through these positions without triggering the process. Once IdleCopy has completed, the backup disk goes back to sleep.

DO NOT remove the external HDD or DVD-RAM until the IdleCopy job has completed (see *Pazienza!*, p.20).

Toggling between TEST and STOP is the way to display the remaining disk space in Gigabytes. If, at the end of your next recording, the file is too large to be idle copied within the available backup disk space, 'IdleCopy Full' appears. After you [eject] the DVD-RAM or remove the CF card, insert an empty one; the backup automatically continues from where it previously stopped.

• Backup@Call

Opens access to the parameters requested for BACKUP.14 'Run Backup'. If you copy your files onto an external HDD, only trigger 'Run Backup' *at the end of the day*; modifying a file's metadata after you have saved the file during the day would not resave the updated file(s) with the next 'Run Backup' of this day. It is preferable to use IdleCopy which resaves files that have been updated.

• PolyStore

To speed-up the end of day 'Run Backup', PolyStore copies onto the int. HDD, the provisional polyphonic files resulting from the treatments done during idle periods or during 'Run backup' on DVDs. From time to time, flush out these poly files from the HDD (see BACKUP.13 'Erase Polys').

02 Day to Copy

2007-02-18

The current day is selected by default. Previous days can be selected too. To simplify archive creation and retrieval, Cantar only copies one day per CD/DVD. Several days can be copied onto an external HDD, each day in turn.

03 TrackSelect

BACKUP 03
TrackSelect
T1-T8 T7T8

T1-T6, T1-T8, T1-T8 T7T8*,
T1-T8 T8T8*, T7T8*, T8T8*.
*of interest if T8 carries a mix-down. (T1-T6 T7T8, later).

04 T1-Tx Trtmt

(for T7T8 alone see BACKUP.05)

MonoDirect PolyNative PolyRotate

• **MonoDirect** leaves the iso tracks in their original form (AB1234_1, AB1234_2), and puts them in an .AAD folder identical to the Cantar HDD one.

Important: Because the Avid NLEs were unable to create automatic links between the iso tracks of a group, it was recommended to import polyphonic BWF-P conversions, not BWF-M files. With the introduction of a new import functionality in MC/Symphony v3.5, MonoDirect is now the best choice.

• **PolyNative** makes long BWF-P poly files (AB1234.PN) by interleaving the iso monofiles while keeping their rank, then stores them in an .AAN folder. • **PolyRotate2** moves the

BACKUP 04
T1-T8 Trtmt
PolyRotate2

tracks two ranks up (the T1-T6 isos go to positions T3-T8, while T7T8 are sent to T1T2), then it makes a poly file (AB1234.PR)

stored in an .AAR folder. PolyRotate2 solves the former Avid MCs inability to put tracks where desired, e.g. when importing a mixdown the MC puts it on the timeline A1-A2, unfortunately it will also put the T1T2 iso tracks of a multi-track recording there too!



Consequently if the editor later decides to import the original T1–T8 tracks, the MC will kill the mix tracks he has been using from day one! Thanks to PolyRotate, the original mix-down tracks (T7T8) rotated to T1T2, will replace the 16-bit poly mixdown with the 24-bit originals, while the native iso tracks (T1–T6), pushed to T3–T8, will gracefully fall into place.

- **PolyRotate1** performs the same operation as PolyRotate2 but pushes the tracks by one rank only: T1–T7 go to T2–T8 while T8 (the Xb mixdown) is sent back to T1.

05 MxDwn Trtmt

MonoNative PolyNative Poly16Trunc Poly16Dith

Only applicable if T7T8 appears in BACKUP.03. This treatment can perform the reduction from 24-bit to 16-bit, convert the T7T8 mono file pairs into poly files and finally store them in an .AAX folder.

- **MonoNative (16&24)** - changes nothing relative to the original 16-bit or 24-bit files.
- **PolyNative(16&24)**: interleaves T7T8 at native bit-depth.
- **Poly16Trunc**: interleaves T7T8, and truncates 24-bit to 16-bit.
- **Poly16Dith**: interleaves T7T8, and dithers 24-bit to 16-bit.

BACKUP	05
T7T8 Trtmt	
Poly16 Dith	

note1: dithering offers a slightly better quality than plain truncation but the process requires twice as much time.

note2: 'treatments' automatically convert 96kHz to 48kHz.

note3: 'treatments' (04 & 05) and track selection (03) are recalled from one recording session to the next; they are lost as soon as the (03) menu bottom row is opened.

06 Media Type

CD±R 700MB Ext.HDD DVD-RAM
 DVD±R 4.7GB DVD+R 8.5GB

It can take more than twenty seconds for a DVD or DVD-RAM media to be checked before its 'one-platter' icon appears in the right circular screen, be patient.

Cantar handles both FAT32 and UDF1.5 formatted DVD-RAM. For MAC/PC compatibility, see SESSION.04 'Disk Format' (p.36), and *Tutorial 2, Drives & Media* (p.43).

07 Burn Mode

Burn Only Burn+Check (Check Only)

Checking a DVD takes just as much time as burning it.

08 FilesToCopy

Unarchived All

Select 'Unarchived' before starting a CD/DVD mid-day copy, this causes the software to look at the 'Archived' flag on the files. Previously copied/archived files flagged as such will not be copied again. 'All' is used to make a second batch of DVDs with all files, previously saved or not.

09 File Name

FiletagOnly With Sc/Tk

FileTag only: **BA1234_1.wav.**

With Sc/Tk: **BA1234==123A 12R w14==_1.wav,**

this brings the scene and take to the editor's desktop.

- Backup on CD/DVD, select 'With Sc/Tk' since long names are supported by ISO and UDF1.5 formats.
 - Backup on ext. HDD, filenames are forced to 'FiletagOnly'; long names are not supported by the basic FAT32 format.
- note:** Majax extracts Sc/Tk IDs from the metadata contained in the iXML and can add them to the files en route to Post on FAT32 formatted HDDs.

10 Media Label

CD 1 of 2

The number of disks needed for the backup is displayed. Press [ok], select the one to burn. [shift] [eye] displays the Media Label created for the disk. CD_MXD_2/5 means: CD-R – Mixdown (Xa · Xb) – Disk #2 in a 5 disk group. The remaining data volume to be burned is displayed.

The large file case

The length of a take can make it impossible to copy it entirely onto one CD. For instance if a 200MB long file comes in with its five brothers (a six-track take), a 1.2GB CD is required. In this case, Cantar separates the take into its individual tracks while minimizing the number of CDs (or DVDs). The label becomes CD_2_D072, where [CD] is the media; [_2] the track #; and [D072] the last four characters of the filename.

Example of a CD/DVD label

An ISO volume label is limited to 31 characters

Cantar#	Project	Date	Archiv	Tag type 1 or 2
099	AAAAAAA	YYYYMMDD	*	CD_T1-6_001



The archive flag (*) is either a (space) or a (#) to show if only un-archived files have been burned; a way to know why some files, probably burned on another media, are missing.

Tag type1: general mode for DVD burning (CD_T1-6_001). T1-6: six mono tracks from the AAD folder, T1-8: eight mono tracks from the AAD folder. MXDN: monophonic stereo mixdown from the AAD folder. MXBN: poly stereo mixdown from AAX folder. MXBC: poly stereo mixdown with 24-bit to 16-bit reduction. 001 to 999: the media rank.

Tag type2: CD_TK-1_001 used if the files must be separated because their group is too large to be burned on a single 690MB CD. TK-1 is the track number and 001 the media name rank.

11 Snap Report (*)

None Direct(mono) (poly)Native (poly)Rotate miXdown
Snap immediately stores the day's Sound-Report into a YYYYMMDD.AA# folder (#= Dir, Nat, Rot, miX) which carries the same status as the backup files (p.38).

(*) based on the SESSION.03 selection, the report is sent to the int.HDD, ext.HDD or both HDDs.

12 Idle Report

No Yes

When the BACKUP 'idle copy' is performed, you must trigger the SoundReport transfer to the idle-copied disc since Cantar has no means to know when you are about to disconnect the disc!

Idle Report copies the Sound-Report to a YYYYMMDD.AA# folder (#= Dir, Nat, Rot, miX) which carries the same treatment as the backup files (p.38).

REMINDER: perform 'Idle Report' before [eject]-ing the DVD-RAM or removing the external HDD.

13 Erase Polys

No Yes

This operation erases all of the previous day's Poly files resulting from intermediary treatments stored in the internal HDD. Obviously if you later have to deliver another backup copy containing Poly files, the Backup@Call will take longer since it will have to recreate the erased files. As a precaution, only the Poly files of preceding workdays can be erased

14 Run Backup

No, nnnnMB Yes, nnnnMB

The default is 'No' with the size of the files to be saved.

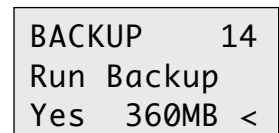

This allows you to quickly visit and immediately leave using the same [ok] button. 'RunBackup' systematically inserts the three

forms of the Sound-Report (ready to print PDF, tab delimited CSV list and ALE list for editing machines) once the backup is completed (p.38).

Example of a standard backup

Select 'T1-T8 (7/8)' in .03, 'mono-Direct' in .04, 'Poly16Trunc' in .05, 'Ext.HDD' or 'DVD-RAM' in .06; you get a Poly16-bit mixdown plus all the native 24-bit monophonic tracks on an external HDD or DVD-RAM.

The several disk case

Go to BACKUP.10 'Media Label', select the disk you wish to burn, [ok], BACKUP.14 'Run Backup', [ok], 'Yes', [ok]. Go back to 'Media Label', choose the next one and so on. You can interrupt the process between two disks and return to it later. Don't forget to write Cantar ID, Project name, Date, and Media label onto the CD/DVD as it comes out, so as not to waste time looking for the ones you haven't done yet! Upon completion of writing, the disk will need to be manually ejected. When the green indicator starts blinking, press the burner's [eject] button.

Direct backup from a Mac or PC

Once TECHSET.01 has 'Unmount'-ed, the internal HDD is no longer under Cantar's control but is still powered; a FireWire connected MAC/PC sees the Cantar HDD as any other HDD, and can copy the files, perform selective erasure, and edit the metadata with Majax. **Warning:** To prevent destruction of the FireWire input (max: 16.6V) by the Mac GX (33V), open the disk cover, take out the HDD and connect it to the GX; its FireWire input handles up to 40V. (Mac/PC laptops supply a safe 12V).

FILE RETRIEVAL the disc's FAT is saved every ten seconds. In case of power interruption, the audio is playable but TC and comments are not saved; use Majax to reconfirm it (see p.56). In case of disk crash or accidental erasure, do not continue to use it, do not try any recovery program, this will destroy any audio that could have been otherwise saved. Instead, contact Aaton.



Where and when storing the SoundReport

Three possibilities

1 Backup@call:

a- when BACKUP.14 'Run backup' is completed the SoundReport is systematically stored with your audio files on the backup media (DVD-RAM, DVD, CD, Ext. HDD, etc) selected in BACKUP.06.

b- the SoundReport carries the treatment of the files themselves, i.e Direct(mono), (poly)Native, (poly)Rotate, or miX, as selected in BACKUP.04/05.

2 Snap report

a- triggered by BACKUP.11 'Snap report', the SoundReport goes to the HDD disk(s) used for Iso recording, i.e Int.HDD, Ext.HDD or BothHDDs, as selected in SESSION.03. It can't go to the DVD-RAM.

b- the selected SoundReport treatment, i.e Direct(mono), (poly)Native, (poly)Rotate, or miX, can be different from the one selected for other purposes.

3 Idle report

a- triggered by BACKUP.12 'Idle-Report', the SoundReport goes to the media previously selected in SESSION.06 for the idle copy, this is done while in TEST or STOP positions.

b- Idle report adopts the same BACKUP.04/05 'treatment' selected for the idle-copy of the audio files, i.e Direct(mono), (poly)Native, (poly)Rotate, or miX.

REMINDER: You must manually execute BACKUP.12 'Idle Report' BEFORE you disconnect or eject the idle-copied drive.

Meaning of the audio folders' .AAD, .AAR, .AAN, .AAX suffixes

- while recording the audio files on either the internal or external HDD or both (as selected in SESSION.03) they all are stored inside .AAD folders as ISO tracks, i.e. monophonic files.

- when backing up the files by any method, whatever the selected media, they are stored in different folders depending on the treatment they received: Direct(mono) go to .AAD, (poly)Native go to .AAN,, (poly)Rotate, go to .AAR, and miX go to AAX (p.39 & p.40).

After the backup is done, it is still possible to make some metadata changes on the discs.

- If your backup has been done on CD or DVD±R, you can't insert any corrections. Redo the burning on virgin media.

- If the backup has been done on a DVD-RAM or an Ext.HDD, it is possible to modify it: FIRST select 'Idle copy' in BACKUP.01 and the drive to be corrected. Go to BROWSE and modify the metadata stored on the Int. HDD. Once done go to TEST, the corrections are transferred from the Int.HDD to the backup drive.

If for some reason you forgot to first select 'idle copy' before your corrections, go to BACKUP.01 'Idle copy', select the backup drive, and go to TEST. As soon as the drive icon appears in the modulometer's center (it can take up to 20sec for a DVD-RAM), the corrections are transferred from the Int.HDD to the backup drive.

It is possible to make a second backup of the workday on DVD or Ext.HDD if you have done an idle copy DVD-RAM during the day.

- DVD: in the evening go to BACKUP.06 'Media type' and select DVD, then in BACKUP.08 'File to copy' select 'All' to allow Cantar to burn the already archived files again. Then go to BACKUP.14 'Run backup'.

- Ext.HDD: in the evening go to BACKUP.06 'Media type', select Ext.HDD. Then go to BACKUP.14 'Run backup'.

"No Store" appears in the rectangular screen.

It reminds you that BACKUP.01 'PolyStore' has been activated but you forgot to select a 'poly' treatment in BACKUP.04/05!

note: "End Stor trtmt" tells you the 'poly' treatment has been successfully stored in a folder of the recording HDD, waiting for your end of day backup@call. From time to time, flush out these provisional files from the HDD (see BACKUP.13 'Erase Polys').

The FAT32 can handle up to 2TB, but Microsoft lets it be 'universal' below 120GB, Cantar formats HDD and SSD up to this value.

Internal HDD

PATA Seagate EE25.2 [ST980818AM] 80GB.

SATA* Hitachi Endurastar J4K100 [HEJ421010G9SA00] 100GB, 4200RPM. Hitachi Travelstar 5K320 [HTS543216L9A300] 120GB, 5400RPM.

When replacing an HDD, verify the static electricity grounding path between the disk housing and the Cantar chassis is within factory specs (120k ohm \pm 20%).

Internal SSD

SATA* OCZ Vertex SS2, 120GB. OCZ Agility [OCZSSD2-1AGT], 120GB.

External HDD or SSD

For an external disk larger than 120GB, use *Partition-Magic* <http://www.symantec.com/norton/partitionmagic> to format a small FAT32 primary partition (e.g. 40GB) and the rest under NTFS (e.g. 210GB). Record the workday onto the 40GB partition; and later transfer the files from the FAT32 to the NTFS partition with your laptop. Hot HDDs are unreliable; use a well ventilated enclosure.

Only firmware v2.24+ can handle a mix of internal - external, PATA - SATA drives.

Flash cards

For idle backup the best is to use SDHC cards (sturdier design than CF, write-protected, MacBook-Pro 2009 compatible). Insert an SD to CF adapter <www.semsons.com/sdtoctyiiad.html> or <www.delkin.com/products/adapters/sd-to-cf/sd-to-cf.html> into a Firewire to CF converter such as Sandisk 'SDDRX4-CF-901' or Lexar 'Pro UDMA FireWire 800'. To erase a card, do NOT DELETE the files, re-format it with Cantar (see p.36).

note: not featuring the SSD's wear leveling (spread of the workload to all cells), CF and SD cards hardly survive the many read/write cycles of audio file recording.

External Device rules

Connect the drive while Cantar is 'OFF' (see p.5).

Run your HDDs every six months; oil bearings of unused HDDs become stiff, imagine the fate of your archives if you don't stick to that recommendation.



CD/DVD Burners

All former CD/DVD burners should be replaced with the Panasonic-Matshita UJ-85J (current P/ATA) or UJ875 (future S/ATA) which burn DVD-RAM and accept 16x DVD \pm R.

Internal: To install a new CD/DVD burner, see p.5. When Cantar goes to REC, the DVD-RAM burner closes its unfinished idle-copy task and generates magnetic interference for a few seconds; that is why it must carry an Aaton mu-metal shield plate in Cantars #001 to #240 (see p.57).

Setting TECHSET.01 to 'Unmount' opens access to the Cantar DVD-RAM internal burner through the FireWire socket; this allows you to edit metadata with Majax.

External: Cantar determines whether an external burner is FireWire connected, if it contains a blank disk and if the internal burner is empty, it will choose the external burner to run the backup.

CD/DVD Disks *never use supermarket branded media*

CD-R: Made by Taiyo Yuden, Maxell 'Pros' are the best.

DVD \pm R: Ask the Post Production supervisor what is his preferred flavor (+ or -). Taiyo Yuden 8x are the best but difficult to find; to print labels, use their "Watershield" disks, they are more water resistant than normal white printables. Cantar burns all DVDs at 4x to improve their lifespan.

DVD-RAM: Panasonic 3x LM-AF-120LE.

CD/DVD Disk Handling

98% of all media failures are caused by poor handling. A dirty (fingerprinted) DVD can still be played but is unusable for recording. Open your thumb and index-finger in a U-shape and hold the blank disk by its opposite edges. Do NOT clean it with a cloth in a rotary motion (best way to destroy a complete track) but by successive radial strokes.

DVD-RAM & the MAC

see Majax, p.56

DVD-RAM disks are read-only on Macs, this prevents modification of the file's metadata. You must install 'WriteUDF' <http://www.softarch.com> and use the Cantar DVD-RAM burner in its TECHSET.01 'Unmount'-ed state.

**The Cantar disk shuttle must be equipped with an Aaton FireWire-to-SATA bridge.*



Surround 5.1

For Schoeps x2 M/S mics or SoundField, there is no need for decoding accessories. The onboard mixer has it all.

Double M/S

By Fr. Musy and Gab. Hafner, Switzerland

Microphone wiring The Schoeps double M/S (L-C-R-SL-SR) head is made of two cardioid and one figure-of-eight microphones, it comes with an XLR7 cable to which a home-made XLR7 to XLR5/XLR3 Y cable should be connected.

- XLR7 (F) 1 = gnd 2 = +M front 3 = -M front
4 = +S front 5 = -S front 6 = +M rear 7 = -M rear
- XLR5 (M) 1 = gnd 2 = +M front 3 = -M front
4 = +S front 5 = -S front (yellow, red labels)
- XLR3 (M) 1 = gnd 2 = +M rear 3 = -M rear (grey)

Routing The XLR5 goes to mic3/4 routed to T3 and T4; 'm-s' declared, their monitoring output is automatically left/right decoded. The XLR3 goes to mic5 routed to T5, panned to center. (See Mic Links 3>4-5, p.31).

Monitoring T3 and T4 mixer faders at 100%: you listen to the front stereo. T3 mixer fader at 0% and T5 fader at 100%, the monitor output becomes the sum of the 'S' figure-of-eight on T4 (a+ a-) and of the 'M' rear mic on T5: you listen to the rear stereo.

It is thus easy to alternately listen to the front or rear M/S, or both, with 5.1 double capsule headphones.

Mixing Launch Pyramix and make two M/S strips, one for the front, one for the rear. Lay down the three track media on the M/S tracks (the Pyramix CW), copy track2 'S front' to track4 which becomes 'S rear', reinject 'M front' onto the surround of the M/S front. You can also make an extraction for the 'sub': here is your 5.1 sound!

Soundfield B-Format

By Phil. Vandendriessche, Belgium

Four channels: X front/back figure-of-eight; Y left/right figure-of-eight; W omnidirectional; Z top/bottom figure-of-eight (seldom used for now since 5.1 is 'horizontal' only).

The Cantar onboard mixer handles the B-Format stereo monitoring with adjustment of the pattern and width.

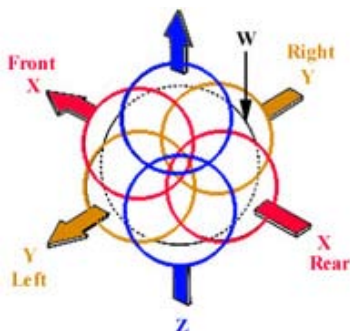

Routing Connect the Soundfield ST350: X output to line1->T5, Y to line2->T6 (T5 & T6 'm-s' declared), and W to line3->T4 (panned to center). The Mic or Line-in gains (1>2.3 ganged) are adjusted to the half dB (p.17).

Monitoring Faders T5 (X) and T6 (Y) at 100% level, makes for a *Blumlein* "stereo pair" (two coincident figure-of-eight microphones angled 90°); adding some T4 (W) to the mix transforms the figure-of-eight components to cardioid (coincident "XY stereo pair". Faders T5 (X) and T4 (W) panned to center at 100% level, and T6 (Y) at 0%, you listen to the left component of the stereo pair. T6 (Y) and T4 (W) at 100% and T5 (X) at 0%, you listen to the right component.

The head rotation simulation in stereo will come in a future version. Put the monitoring black crown to 'B'. To listen to the front, select 'Fs'. To turn the head 90° right, select the 'Rs' config (inverted Y in the mix); to turn the head back, select 'Bs' (inverted X & Y in the mix); to turn the head 90° left, select the 'Ls' (inverted X in the mix);

<http://www.soundfield.com/soundfield/technology.php>

Mixdown with decoded M/S (or not)

The mixer faders and pan-pots feed the mixdown (Xa Xb) tracks. The inputs are routed to the six tracks; an M/S pair is connected to mic3 & mic4 and routed to track5 & track6 ('m-s' declared). The M and S signals are recorded as metered on the T5T6 modulometers and stereo decoded into the mixdown output. If the editor prefers not to get stereo signals in his reference sound, pan the M track to one side or the other: the S track will disappear from the mix.

Documentary style with M/S background

The boom-mic on M5 in its island naturally falls under the right hand. The 'active' RF mics go to M1, M2 on the front row, and the peaceful RF mic goes to L1. The M/S pair on M3 & M4, routed to T5T6, is displayed on the right screen shared with the T7T8 mixdown.

Boom -> M5 -> T1; RF calm mic -> L1 -> T2

RF1 active -> M1 -> T3; RF2 active -> M2 -> T4

L or 'M'-mic -> M3 -> T5; R or 'S'-mic -> M4 -> T6



The boom and RF mics

The boom, connected to M5, is directly routed to T7 (see *Create T7T8 IN-GRIDS*, p.28). The RF-mics, routed to T1–T6 (panned to the right), go to miXb on T8.

Proper Mixing

The following communication, sent to the Cantar User's Group by Marc Weber, is a must read:

Date: Sat, 3 May 2008

To: Cantar Users' Group <cantar-users@aaton.com>

Subject: Proper mixing

Are you all saying that we should not be mixing just because we are providing isolated tracks on mono files?

As a mixer it is my assumption that my job is to mix so that phase anomalies are not occurring and mixing out unwanted open mics so that a useful production mix is always present and if post wants isolated mic tracks then that is what I deliver on top of the mix.

What am I missing here?

Phase interferences are only audible at specific relationships between pairs of microphones and at a specific balance between them, usually a 50/50 balance as with boom and radio mic. If three mics are open, the phase interference is a result of only one of those mics in reference to the other two.

Assuming I am mixing to a mono track with one boom and one radio and at a certain point there is phasing, I would be rocking the mix back and forth favoring either the boom or radio. If the phasing occurs when both mics are at unity then I never allow unity to occur.

As a wired actor walks into a room and comes forward approaching a boom mic, I would be favoring the radio until the actor steps into the sweet spot of the boom at which point I would crossfade, potting down the radio as I pot up the boom.

This does not necessarily mean that I completely turn off either mic at any time but only prevent the 50/50 balance of the two from occurring, or maybe once the actor reaches the boom sweet spot and stays there for the rest of the take then perhaps I slowly fade out the radio mic completely, to prevent clothing rustle or some other physical noise.

Same thing if mixing two actors on radios with no boom and as they turn to face each other there is a phasing taking place between them, then I would be crossfading the balance between them back and forth favoring the mic of the actor that is speaking, again never allowing the 50/50 balance to occur but always keeping both mics open unless some action creates a problem like someone pounding themselves on the chest where the mic is placed. Always 60/40 or 75/25 or whatever works. Maybe as the two actors stand very close to each other one of their mics may work to cover both of them.

Now if mixing to two tracks and splitting boom away from the radios then I monitor the split track mix in mono and do all the same things as mentioned above so that if the two tracks are summed together by telecine for dailies or elsewhere in post the resulting mono mix works perfectly.

I hate to allow post the opportunity to screw up my mixes so I always try not to give them the option. If there is no reason to split tracks then I do not do it.

Mark Weber C.A.S.
Sound Specialist Inc.
Miami, Florida

On location

To later reunite images and sounds, *a common TC must be stamped* on both:

1 Activate the Cantar AutoSlate, the clapstick sound is detected and given a TC displayed on the sound report; this TC, keyed by the editor on the image of the clapstick, will then be used as if the camera was timecoded. This is the simplest and most accurate method ever invented. You can also use a Smart-Slate (the recorder sends its TC to a display filmed at the head or tail of each take), but this is not as accurate as the AutoSlate.

2 Send the camera 'Video-TC' to the recorder set in 'Ext. Clock' mode and 'record-slaved' by LTC breaks (p.21). This method is seldom used since it can't work on multi-camera shoots, and relies upon a cable or radio link.

3 Install an Audio-TC generator (Ambient or Denecke) with tri-level sync to replace the camera's internal Video-TC with an external Free-Run Audio-TC identical to the recorder's TC. This method is not applicable to all video cameras; it doesn't let the camera generate a continuous Video-TC, something necessary to some editing systems. It will work perfectly the day all video-cameras and NLEs are designed for it.

4 Record the TC of the audio recorder on one audio track of the camera(s), preferably "A3" (on a two-track consumer camera, record audio on A1 and TC on A2, listen to the A1 audio with a mono-jack). The TC can be sent by cable (clumsy but cheap), by radio (beware the interferences) or locally delivered by a generator such as a GMT (p.55) attached to each camera (use a line input; turn 'OFF' the automatic-gain if you use a mic-input). *Method-4 works on all types of cameras, gives total freedom of movement for multi-camera shooting, and leaves the continuous Record-Run Video-TC (different in each camera) untouched. This is of great value when it comes to batch digitize videotapes under the 'Optimize for Speed' mode.*

In the edit suite

This tutorial is dealing with on-location 'Method-4' only. When using a multi-track recorder, the common practice is to deliver six iso tracks and a mixdown on two extra tracks. This mixdown is also sent through Line-out or Digi-out to the camera's A1 A2 audio tracks to let the director immediately verify the last take and to later look at the day's rushes. Because of a MediaComposer limitation which forces the editor to make a drastic preliminary choice between using or not the camera recorded mixdown, the successive states

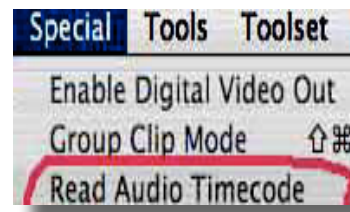

of the post-chain must constantly deal with this duality.

A- Import audio

- *editing with the Cantar iso tracks*

Demanding editors work with all of the iso tracks (including the mixdown) to insert wild tracks or emphasize the presence of an audio event left unheard within the mixdown. In this case the video material should be imported under the **V A3** mode (not V A1 A2 A3 which would import the camera recorded mixdown, thus preventing later import and autosync of the iso tracks).

Once editing is done, the Audio-EDL 'TC sorting' will be done with *Filetags*, the assistant editor must put them in the Avid 'soundroll' column prior to the import.

- *editing with the camera recorded mixdown*

If the editor prefers to work with the camera recorded mixdown, the import must be done under **V A1 A2 A3**: the audio is coming from A1 A2 and the Audio-TC from A3. Once editing is done, the Audio-EDL 'TC sorting' will be done with *TapelDs*, the assistant editor must put them in the Avid 'soundroll' column prior to the import.

B- Extract TC

During the import digitization, Avid MediaComposer/ XPressPro and Apple FCP w/ AUX-TC-FCP can extract the Audio-TC from A3 (or from A2 on a two-track only consumer camera). The Audio-TC, correlated to the Video-TC, doesn't occupy an audio track of the NLE system. It will be used to 'Autosync' imported iso tracks and to construct the Audio-EDL (Edit Decision List). Read the 'PostChain':

<http://www.aaton.com/documentation/>

C- Differentiate TCs

- *editing with the Cantar iso tracks*

No problem here: each audio file carries its own *filetag* in which it is impossible to find two identical TC(h).

- *editing with the camera mixdown*

There are no 'filetags' in the camera recorded mixdown, the only link with the Cantar iso tracks is the Audio-TC. But because the CMX Audio-EDLs generated by NLE systems don't carry the Audio-TC(d) date, the Audio-TC(h) every day shows the same working hours: it can't offer a solid 'auto-conform' path from the edited mixdown to the original Cantar iso tracks.

The 'User's TapeRef' solution

The trick invented by the video people to hide this failure is to differentiate identical TC(h) by manually entering the camera's 'VideoTapeID' into the editing databases... and they now try to impose this old fashioned 'cassette minded' system to the audio file sorting too! (note1). To avoid this misfortune, Cantar reintroduces the TC 'date' that CMX's EDLs killed, by replacing the arbitrary 'VideoTapeID' entries with the automatically generated MMDD 'User's TapeRef'; no longer bothering the sound recordist with video cassette or P2 IDs, this eliminates fat-finger errors, and furthermore takes care of multi-camera shooting.

User's TapeRef, Cantar side

Using the workday which gives a name to the Cantar folders, the MMDD (month/day) is automatically stored in the 'User's TapeRef' metadata field of each audio file. As an alternative to the absolute date, some productions do prefer to enter manually incremented shooting days, this is not a good idea! see note2.

User's TapeRef, Camera side

The camera operator writes the six character 'VideoTapeID' on the video cassette, compact-flash or disk, like in the good old times, but instead of an arbitrary name he writes: MMDD/CamID/Cassette# :

Date: **April 18**, Camera: **A**, Cassette: **9** → **0418A9**

Date: **April 18**, Camera: **B**, Cassette: **1** → **0418B1**.

The 1 to 9 then A to Z last character can identify 35 cassettes per day per camera... long working hours!

User's TapeRef, NLE side

The assistant-editor keys-in the six characters of the standard 'VideoTapeID' when preping the digitization of the cassette, they will appear in the 'TapeID' (or SoundRoll) column of the bin. Please note that if the 'VideoTapeID' sticker is lost or not existing, it is easy for the assistant to replace it by writing the MMDD of the shooting day followed with an import arbitrary incrementing #.

User's TapeRef, final mix side

- To perform the auto-conforming of the Cantar iso files to the edited mixdown, **Titan-3** (p.56) first sorts them by comparing the leading MMDD four characters (0418) of the EDL's 'TapeID' (or SoundRoll) column with the 'User's TapeRef' found in the audio files metadata, then uses the timecode in- and out-points to finish the job (with **Pyramix** you don't even need to use Titan).

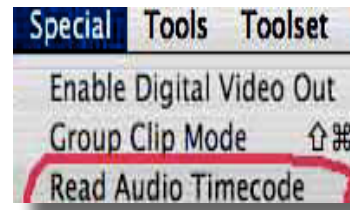

D- Autosync

- editing with the Cantar iso tracks

Correlated to the Video-TC of the images, the Audio-TC is used to 'autosync' the imported Cantar iso tracks and the video pictures. Both TC(h) and TC(d) must match.

- editing with the camera mixdown

Autosync is not applicable since the mixdown has already been linked to the images during their import.

E- EDL generation

- editing with the Cantar iso tracks

Once editing is done, before triggering the Audio-EDL generation, the editor selects **Filetags** (file-names) as the file sorting mode.

- editing with the camera mixdown

Once editing is done, before triggering the Audio-EDL generation, the editor selects the classic 'TapeID' (or SoundRoll) as the file sorting mode.

note1: A demand to be resisted, some producers ask sound recordists to enter the camera/cassette IDs in the 'User's TapeRef' field, this is no good: **1-** quite often the sound recordist is warned too late of the camera cassette change-over. **2-** with video cassettes being replaced by cards, it becomes almost impossible to keep track of them. **3-** on a multi-camera shoot, there is no provision to enter double or triple camera cassette IDs into the metadata. **4-** like any manual operation done in a hurry on location, this is error prone and induces confusion and delays in Post.

note2: The 'Shooting Day Rank' manual entry increases the risk of human error, if you nevertheless use it instead of the absolute date, go to the Tape-Ref field following Comments in PPR 'edit'. First thing in the morning, right after accepting a 'new day', go there and overwrite the MMDD month/day with the 'day rank', e.g. day twenty-five = D025. On the camera side, the assistant writes D025(B1) instead of 0418(B1) on the video cassette.

note3: With Majax, you can batch modify the 'User's TapeRef' field by highlighting all the concerned files and entering the new value in the bottom-right field. It is recorded in the iXML metadata and insures that whatever happens to your files, e.g. mono to poly, mixdown, gathering in a different folder, copy to DVD..., they will keep their 'User's TapeRef'.



To **activate** the Rec&Play BLUE functions, press the blue [shift] button while transitioning to a new [MainSelector] position, hold it for one second after the position has been reached. In BlueRec (p.23), Cantar **plays** up to eight tracks from the internal or external drive while it **records** a selection of these tracks (*routed through the digital inputs*), along with the 'live' audio coming through the analog inputs.

Two operating modes are available in the BLUE-BRWS 21 menu.

Live mode

The TC, scene & take IDs, comments, and track-names are those of the 'live' take. We have identified two main applications for the live mode:

- **Classic playback:** telephone call, background music or wild sounds stored in *play-cards* (p.24) are played and re-recorded (or not) during the 'live' recording.
- **ADR-1:** known as 'hear it/say it' this function lets the actor record his replacement dialog *right after* listening to his former lines followed by a 'say it' buzz.

In live mode the 'live' file (the one being recorded) and the playback file carry a different TC and a link, called a 'Linking-Trio', is created between the two files. This Linking-Trio is stored in the iXML of the live file. It stores the TC (1) and the filetag (2) of the play-back sound along with the current TC (3) of the live file. Linking-Trios are used later in the Avid MC to link & sync the playback sounds with the live ones. A message, 'Played filetag(s) AB1234, XY9753', appears in the comment line of the PDF Sound-Report and helps the editor find the original tracks by supplying the filetags to be used in the file search.

Do not forget to send your original files to the editor! Because of the Linking-Trios sub-frame accuracy, and the 'command-to-play' zero delay, Cantar outperforms the External Player/Music-Slate couple.

Clone mode

In clone mode a new filetag is attached to the 'live' file (you will never run the risk of erasing the master). The play back and the 'live' file will carry the same TC and metadata. We have identified three main applications for the clone mode:

- **Remix:** make a copy of the original iso tracks and perform a new mixdown with the onboard mixer or the Cantarem. This also lets you insert a simultaneous translation of the dialog.

- **ADR-2:** while listening to the guide track (text or pre-recorded music), the performers record their dialog or song (alongside the guide track) on the other tracks. The TC of the played file can be sent through the LTC-output to a video camera or chasing VTR.
- **Re-recording:** with its short 0.4 msec 'Mic to Phones' latency, Cantar is good at incremental recording, i.e. adding one track while listening to the previous track(s) to produce 'packs' of eight tracks which are easy to stack later because of their identical TCs.

Rec&Play, steps to perform:

- 1- choose the HDD (int. or ext.) and the project folder containing the files to be played.
- 2- attach an index (A to L) to your selected playback files.
- 3- create play-cards (up to 51) in each indexed file (play-cards are sections of the playback file).
- 4- prepare the Routing: route your analog inputs to the tracks, as well as the playback sounds which are internally sent to the Digi-inputs and routed as such (see Rec&Play In-Grids, p.28).
- 5- test each routing and each play-card selection by going to BLUE-TEST before the real Play&Rec done in BLUE-REC.

Playback-file indexing

CantarX1 & X2

Go to BLUE-BRWS (see p.10), select the audio files needed for your Rec&Play operation, and convert them into **Playback-files** by putting them under indexes **A** to **L** (p.25).

A B indexes are reserved for the *current day* folders of the *current project* files, **C D E F** are reserved for *any day* of the *current project*, **G H I J K L** are reserved for *archives*, e.g. wild

tracks, music, etc., stored on external or internal HDD.

Please note that **archive** play-files must be grouped on the same drive (most of the time an external drive), same project, same day. Play-files which are no longer available, e.g. files stored on a disconnected external disc, carry an **'n.a.'** suffix instead of **'ok'**.

Go to BLUE-BRWS.21 'TC mode', select **Live** prior to a 'live' mode session or select **Clone A** (from A to L) prior to a 'clone' mode session.

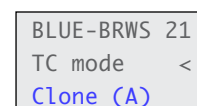
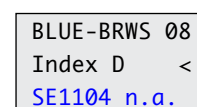



Play-card creation

Cantar-X1 & X2

1- Go to BLUE-PLAY (see p.10), then with [shift] [>], choose a Play-file among the **A to L** (1) displayed top-left of the rectangular screen.

2- With [<] or [>], select an empty card among the **A00..A51** (1) cards.

The factory A00 card contains the entire play-file; it does not store cues-in entered for test purpose; the non-modifiable cue-out is the take duration.

3- To fill an empty card, e.g. A01, scrub the audio time-line (4) by [jog], press the [black] button to set a cue-in (3), scrub further and press the [gold] button to set a cue-out (7); a **half**

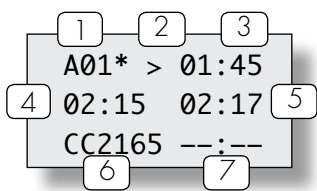

second mute is inserted at the cue-out to let you fine tune its position. The last entered cue-in or cue-out points replace the former ones.

Once a cue-in is entered (cue-out not necessary), an empty card becomes a **play-card**. The cue points are stored in the iXML of the file and will only be removed by erasing the play-card; to do so, [jog] to 00:00 and press [gold]. To **hide** a play-card without erasing its cues, press [shift] [gold]; tagged with a '*' the card is no longer visible in the BLUE-TEST/BLUE-REC play list, shortening it.

4- With [>] select a play-card and press [ok] to play it from its cue-in. If there is no cue-out or if you want to stop the playback before reaching it, press [ok]. Press [ok] again to restart from cue-in. Press [esc] to pause, press [esc] to resume play.

note: when going to BLUE-PLAY, take your time while passing over STOP! If the message **'you were too fast'** appears, go



Play-file 'E' from the archives, six play-cards (E34 hidden). Note their overlapping placement, suitable for 'classic playback'

back to STOP for one second.

note: The Rec&Play metadata is stored in an iXML v1.50a chunk compliant with Cantar v2.11 or later. To **update** old style files, see p.25.

Rehearsal

As soon as BLUE-TEST is activated, the playback tracks (Tp1 to Tp6), are internally sent to the digi1-8 inputs from where they are routed the standard way (see *Rec&Play In-Grids*, p.28). Adjust the relative levels of the digital inputs (Tp tracks) and analog inputs, then rehearse your intended BLUE-REC navigation (see *Playback* below); the last BLUE-TEST selected play-card is the first to be played.

TIP: in BLUE-TEST you can go swiftly from one play-card to the next to let the film-director verify the 'hilited' segments of a take without scrubbing through the entire file.

note: Rec&Play works at 48kHz (±0.1%). The play-files are played at the 'Live' recording sample rate, quite useful on filmed music shows transferred to NTSC.

To import MP3s into your archives, see p.25.

Live recording

Select 'Live (all)' in BLUE-BRWVS.21

Playback

In BLUE-REC, the analog inputs are recorded the standard way. To play the first play-card, press [ok] (or [space] on a keyboard). To stop before reaching the card's cue-out, press [ok]. To replay from the cue-in, press [ok]. To pause, press [esc], to resume, press [esc].

To reach the next card, two possibilities:

1 browse the **'view'** tagged play-files with [shift] [>], then select the desired **'*'** tagged play-card with [>];

2 connect a PS2 keyboard and type the successive card IDs (B12, F45, A08), then [enter]. Tarkan (p.51) can be of tremendous help here.

ADR-1

(same as above). The actor listens to the play-card containing the lines to be replaced. A buzz is heard in the headphones at the play-card's end to warn him to start talking. Without stopping the live recording, the operation can be repeated again and again to satisfaction.



Clone recording

Select 'Clone' in BLUE-BRWS.21

Copy, Remix & Translate

To copy an audio file with an updated iXML chunk for the archives, select In-Grid **RPA** (p.28). To redo a mixdown with the onboard mixer, select In-Grid **RPM** (p.28) in which the Xa Xb mixdown goes to T7T8.

You can add a simultaneous translation of a scene by either routing two digi-ins to the same track and sending the translation mic to the 'freed' track, or selecting **RR7** in which 'mic5 Xb' records the translator's mic on T7 and the mono-mix on T8.

The selected play-card plays at BLUE-REC start, **Ptc** (Playback TC) replaces **Stc** on the control screen. There can be only one TC stamp per filetag, if you want to Remix a portion of the original file, go to BLUE-PLAY, create a play-card then return to BLUE-REC which creates a new filetag. To abort the cloning, go to PPR and erase the file (see *Last take erasure*, p.20).

You can continue to record after the end point of the cloned file but there is a risk that this 'tail' generates a timecode overlap with the next original take. To get a clone of the same exact length as the original (same start and stop TC)*, go to BLUE-PPR and trigger the recording with the keyboard [ctrl] [alt] [r]; it will stop on the original file's end point.

** To avoid later auto-sync confusion between an original recording and its remixed clones (they all share the same TC&Date), go to BROWSE and trash them all but the best remix to be sent to the editing room. Since they are kept hidden in the day's folder, you can revive them later.*

ADR-2

While listening to the cloned guide track(s), and watching the images of the original shoot (Ptc 'Play TC' is used to sync a chasing VTR by LTC), the performers re-record their dialog on a new set of tracks.

Re-Recording

Under In-Grid **RR1** (see *In-Grids*, p.28), record your first track in normal REC. Go to BLUE-BRWS.04 and put the filetag of your best 'track1' recording (not always the latest one) under '**Index A**'. Select '**Clone A**' in BLUE-BRWS.21, then under In-Grid **RR2** go to BLUE-REC and record 'track2' (as many times as needed); then go to BLUE-BRWS.04, and put the filetag of the best recording under '**Index A**'... and so on, up to **RR8**. You get an eight-track incremental recording in the last recorded filetag.

Cantar full remote

for Cantar-X2

Installed in a netbook (1024*600 pixels minimum), the free Tarkan application controls all of the Cantar's audio flow, edits metadata, and generates PDF & CSV sound-reports through an Ethernet CAT-5 connection. TAW114 (Win-XP) or TAM114 (OS-X) are on the Aaton download site (see p.3).

starting-up

Cantar side: Turn 'OFF' Cantar, plug a straight or cross-wired CAT-5 cable into the socket in the HDD housing. The cable must be held tightly by the canyon shaped clamp.

Laptop side: First eliminate any other TCP/IP activity (note1). Connect the CAT-5 cable. Turn 'ON' Cantar. Launch the Tarkan application and **wait** from 10 sec (Mac OS-X) to 60 sec (Win-XP) to allow Tarkan to assign an IP address to Cantar. Then click the upper/left 'start' icon

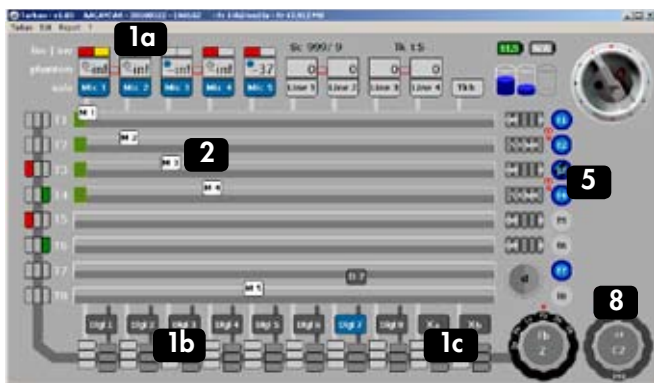

main screen

The screen is made of three layers: the first one displays the audio flow from the digi/mic/line inputs (with their settings), to the tracks (IN-GRIDS) and to the monitors (OUT-MAPS), the second layer handles the mixer with its faders (carrying the track-names) and panpots, the third layer displays the modulometers over the tracks.

In-Grids

The analog inputs (1a) go down, the digital and mixer inputs (1b/1c) go up to the track cross points (2). To set the inputs for T1-T6, go to ROUTING IN-GRIDS (8), click on the desired cross point, it turns blue; double click to deactivate. To set the inputs for T7T8, first click the desired T7 cross point, it turns yellow as well as the other possible choice(s), click the other one: they both turn blue. To turn 'OFF' T7T8, double click the cross point routed to T7. Armed tracks (5) are high-lighted in deep blue.

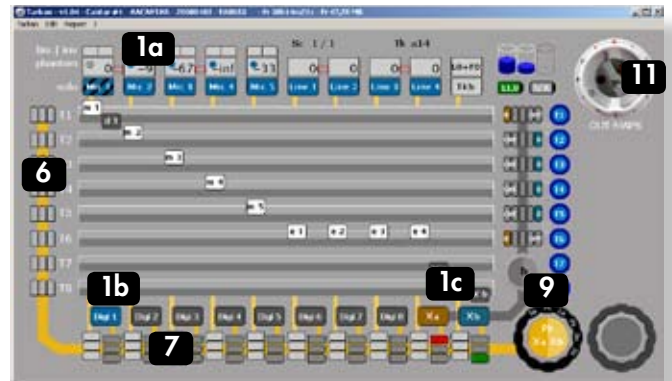

Out-Maps

The tracks go to the 'left-center-right' track monitoring switches (6). Analog and digital inputs go directly to the "input monitoring" switches (7). Both (6) and (7) go to the monitoring crown (9).

Mixer

The mixer's faders (3) and pan-pots (4) generate the mix-down input (1c); In PPR, TEST and ROUTING (IN-GRIDS), twenty-six pan-pot configurations can be stored in Tarkan.

- During the creation of a pan-pot config, either on Cantar the usual way, or on Tarkan with successive clicks on the colored beans (100% left/right with [ctrl] [click]), the background of the pan-pot 'crown' (10) becomes **red**. Once done, a [ctrl] [click] in the middle of the crown stores the config in Tarkan's memory and pushes it into Cantar where it becomes the active mixer pan-pot, as indicated by the crown background which turns **grey**.
- Labeled from a to z, all the pan-pot configurations are stored in Tarkan memory where they are displayed against a **green** background. Browse them by clicking the left or right half-moon. A [ctrl] [click] in the middle of the crown pushes the selected config into Cantar: becoming 'active', it turns from green to grey.

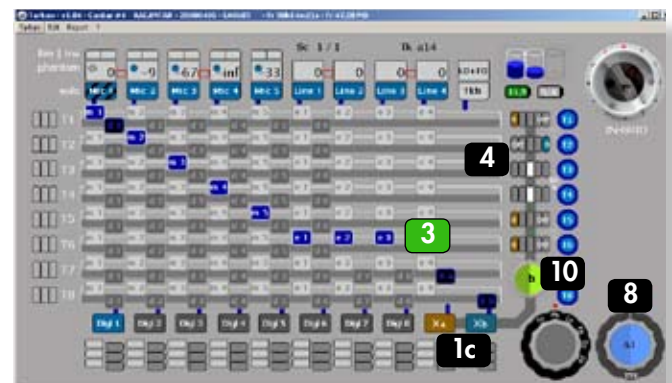

Remote

To get access to all of Cantar's functions, physically set the [MainSelector] to PPR, then click on the desired position of the VirtualSelector (yellow circle turns red) (11).

Rec&Play

The VirtualSelector turns blue when a Rec&Play 'BLUE' function is called by pressing the keyboard or Cantar [shift] button. The panel (12) is used to select and activate the play-cards.



metadata screen

For paradigm consistency, metadata are presented in the same lay-out as the Cantar Sound-Report ((except that the most recent takes are on top of the page). They are either



immediately written in the open audio files (REC: black characters on yellow background, PPR: orange background), or stored in a buffer memory if the files are closed or inaccessible (red characters on grey background), waiting to be 'pushed' to the connected Cantar in physical or virtual BROWSE positions.

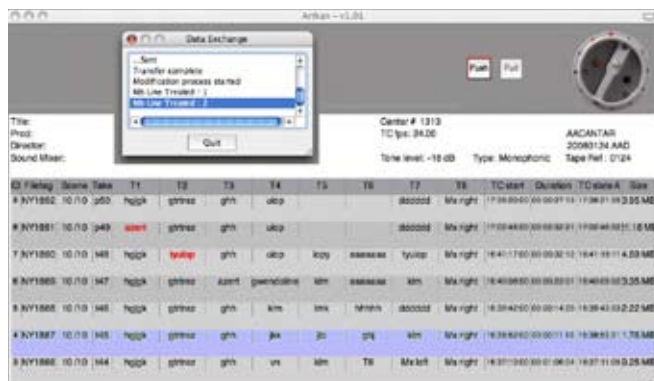

Access to the 'Metadata' screens is allowed on the positions where the MainSelector bottom becomes dark grey; double click on the selector itself.

operands screen

This screen gives access to the AUDIO/TC, TECHSET, SESSION and BACKUP parameters. TECHSET 'Save Setup' stores the saved parameters in the Cantar memory.

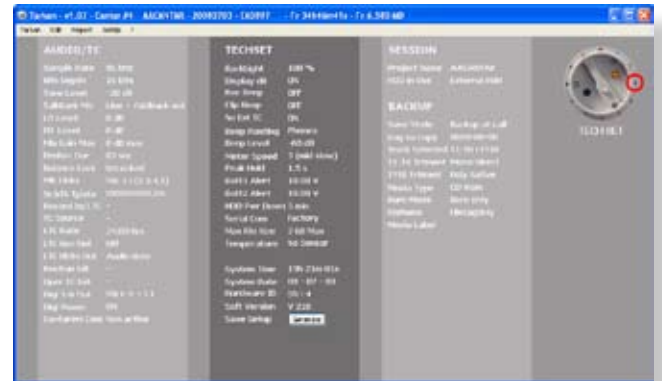

note1

•Disable the firewall. Consult your Mac manual since the procedure is different for OS-X 10.4 (Tiger) and 10.5 (Leopard). Either 'allow all connections' or 'allow specific' i.e. Tarkan. • Before launching Tarkan, make sure that no TCP/IP activity is occurring: turn 'OFF' your Bluetooth and WiFi apps; quit Skype, your e-mail client, all widgets and anything else that is scanning the internet.

Tip by Tim White: If you are using your usual laptop for Tarkan, instead of turning off internet scanning apps, set up another user which you log in as just for a Tarkan session with all the correct parameters and log back in as the usual user for normal use.

Tip by Jean Casanova: Every time your laptop wakes-up, it takes a few seconds to get a dynamic IP; to avoid this, assign it a fixed IP. Open the local network properties, enter 'Tarkan Connection' instead of 'Default Local Connection'. Double-click "Internet Protocol" (TCP/IP): Address 169.254.213.29, Network Mask 255.255.0.0, leave the rest blank. It takes 4 seconds for Tarkan to talk to Cantar.

note2

A PDF/CSV sound-report builder is implemented. PDFs from Tarkan save time at wrap up.

Connections

If the Cantar motherboard is CM2.6+ (the ID appears under the white sheet in the HDD housing, and in TECHSET.23 'Hardwr IDs'), the CantaRem to Cantar ASCII connection is insured through the Cantar's SubD15 pin-2. Use a 'SubD15 to Lemo8' cable (ref. 594 4090).

If the motherboard is earlier than CM2.6, the SubD15 pin-2 is not internally connected to the ASCII port; you must use a 'SubD 15 to Lemo 8+Lemo 5' Y cable (ref. 594 4191), and connect the Lemo 5 plug to the Cantar timecode-in Lemo5 socket.

- To gang two CantaRems, use the Fischer4-Lemo8 cable (ref. 594 4092). The Fischer4 plug goes to the first CantaRem, the Lemo8 plug goes to the second one.



- | | | |
|---|-----------|---|
| A | Lemo 5 | ASCII – LTC In/Out |
| B | USB | PS2 keyboard |
| C | Fischer 4 | PDA power (or CantaRem '1' to '2') |
| D | Lemo 8 | Connection to Cantar (or CantaRem '2' to '1') |

- The CantaRem USB socket (max 80mA @5V) can't power a PDA; it can feed a PS2 keyboard only. But you can use the +Batt delivered by the Fischer4 socket: terminate the PDA delivered car-lighter converter (Batt →5V) cable with a Fischer4 plug (pin1=Gnd, pin4= +Batt [max 100mA]).

RemFaders' assignment

- If AUDIO/TC.20 'CantaRemCom' is set to 'Inactive', AUDIO/TC.21–36 assignments are not accessible; to modify them before hand, set AUDIO/TC.20 to 'Active'.

To modify assignments with CantaRem, press one of the [ctrl] keys, 'Assign' appears on the top row of the Cantar rectangular screen, press and hold a RemFader key (1 to 8), the RemFader's number is displayed on the middle row; use the [jog] or [>] to browse the Cantar faders displayed on the bottom row:

unused, mic1, mic2, mic3, mic4, mic5, line1, line2, line3, line4, track1, track2, track3, track4, track5, track6, line-out, foldback. The assigned fader is the one displayed just before releasing the key.

note: CantaRem no longer links lines1-2 or lines3-4; a greater choice is offered in AUDIO/TC.09.

- To control several mic or line input faders from the same actuator, link them in the usual Cantar way (see AUDIO/TC.08–09) and assign the actuator to the master only. The slaved *mic faders* can be used for the 'balance', whereas the slaved *line faders*, totally deactivated, duplicate the gain of the master.
- The last assignment of a CantaRem RemFader previously linked to another Cantar fader cancels the former link. All Cantar physical faders are re-enabled as soon as CantaRem is disabled by setting AUDIO/TC.20 'CantaRemCom' to 'Inactive', or by unplugging the cable. Stored assignments are displayed on AUDIO/TC.21–36.
- To activate the solo monitoring of a mic, line or track, press the key of the RemFader controlling it
- The 0.6 second delay of Cantar's line faders is more apparent when they are driven by linear actuators which, unlike the Cantar onboard faders, can be swept from 0 to -60dBFS in a wink.
- Put Cantar's [MainSelector] on STOP to initialize its clock by ASCII from an OriginC.
- Cantar remote: [MainSelector] on PPR, set AUDIO/TC.20 'CantaRemCom' to 'Active'. Press both [ctrl] keys, and press [2]: TEST, [3]: PPR or [4]: REC. When 'CantaRemCom' is set to 'Forced', [1]: STOP is also available.

Design considerations

- Since Cantar is the only audio recorder featuring a wireless PDA link, there is no need for a 'replica' display nor a built-in keyboard on CantaRem.
- CantaRem's Penny+Gilles faders are feather-smooth, but not as resistant to the elements as Cantar's magnetically driven faders. That is why CantaRem is built with structural transparency, allowing sand and water to freely flow through.
- The precise gain value of each fader is displayed on Cantar's rectangular screen, the actuators' 0 to 9 scale is only a quick positioning aid.

Functions

- Remotely controls Bluetooth equipped Cantars in TEST, PPR and REC
- Sets input and output routings
- Displays modulometers and fader gains
- Edits scene, take, take-type, comments and tracknames. Arcan-W runs under Windows Mobile 5, not Mobile 6. Arcan-P for Palm-OS is no longer maintained, i.e. the remote-record function has not, nor will it be, implemented in this application.

Installation



The Win-Mobile5 PDA must feature a VGA screen (640x480), not a QVGA screen (320x240), and an MS Bluetooth stack, not a Broadcom stack, e.g. Qtek 9000, DELL Axim-51v, HTC X7500, Fujitsu Loox N560.

Download 'rcan_214.cab' from the Aaton web site to a PC or Mac and copy it through USB into a folder of the PDA. Then open this folder and execute 'rcan_214.cab'.

Connection to Cantar

Cantar side Set TECHSET.17 'Serial Com' to 'Bluetooth'. The 3m range Cantar transmitter is low power (Idle: 0.1mA, Connecting: 4mA) and may remain active at all times.

PDA side Click Arcan's icon in the PDA 'programs' screen.

1. **Select a Link:** Bluetooth. 2. **Search:** found Bluetooth devices are shown in the 'Pick one' pulldown menu; click the ID for the Cantar you want to store in the PDA memory. 3. **Pick one:** the list of Cantar IDs in memory is shown; click the desired one. 4. **Connect:** the latest Cantar ID will show at next connection. 5. **Status:** for maintenance engineers.

Working Screens

Arcan-w displays the modulometers, prefader and mixer gains, plus the mic-preamp settings. It sets the ins and outs routings, and enters/edits scene, take, take-type, track-names and comments.

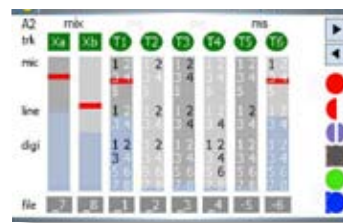

1 In-Grids

track (dis-)arming (file rank becomes light grey), m-s status, inputs to tracks routings can be modified in STOP position.

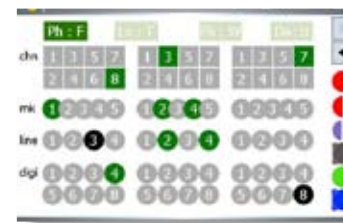

2 Out-Maps

recorded signals appear in green; the non-recorded, sent directly to outputs, appear in black. Outputs mapping can be modified in STOP position.

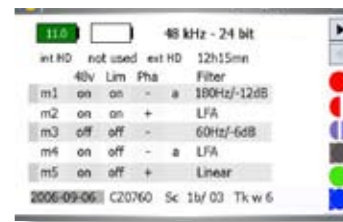

3 Physical parameters

top: battery voltage, sample rate and bit-depth, internal/external disk recording time. **middle:** phantom, limiter, phase, high-pass filter in STOP position; fader/mixer gains in TEST, PPR and REC. **bottom:** date, filetags, scene, take, and take-type.

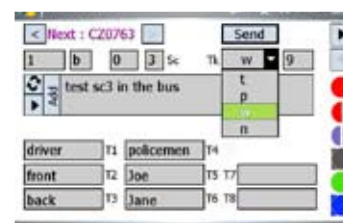

4 Metadata editing

Scene, take, take-type, comments, and track-names with auto completion and memorized text insertion are edited in REC, PPR and BROWSE. To erase older comments, go to the bottom-left field, toggle from 'Pen' to 'Trash', your stored comments appear over a red background; click to erase.

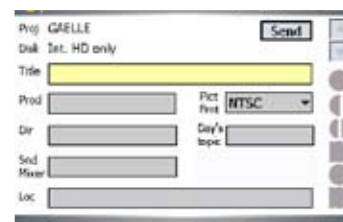

5 Sound-Report editing

Arcan-w is a great helper to enter and modify the Sound-Report's headers. Several entries per day are allowed. A new .ALE page, a new .CSV page and a new Sound-Report page is opened anytime a header item is changed.

See the complete Arcan-w user's instructions on <http://www.aaton.com/products/sound/arcan/index.php>



OriginC master-clock sets cameras and recorders TC

Start OriginC by pressing the [#] key. Enter all of the Prod ID digits, Date and Time. Press [#] to scan through the display. All fields being set, press [*] to start the clock. To shut-down, press [#] for five seconds until 'Stopped' appears.

ASCII initialize Cantar, cameras or other machines with ASCII (an fps

agnostic protocol), plug the Lemo 5 into the LTC socket of the machine, press [#]. OriginC's answer back should be 'good 00.0'.

ASCII check a camera clock, press [#]. OriginC displays 'good' 'fair' 'bad' or 'diff-time', followed by the amount of drift in frame tenths.

LTC init a machine with SMPTE LTC, simultaneously press [#] [0].

Get or check LTC generated by a IVS-TC, Fostex PD6, etc. or to simply read external timecode, press [*] [2].

Send continuous LTC to a non-TC recorder, press [*] [1], OriginC generates

a SMPTE LTC signal to be recorded on an unused audio track.

Select 24, 25, 30fps SMPTE LTC out, press [*] [4], then [#] to confirm.

Technical Specifications

- 1 ppm TCXO, ±1/2 frame shift after four hours
- Six hour automatic-shutoff
- 150 hours on a Li-Ion 9V battery.
- 180x90x20mm. 375gr.

Order an Aaton L5-XLR3-SCH cable for connection to LTC XLR3sockets.

Lemo 5 plug (ref: PHG OB-305-CLLD42)

- 1-Gnd
- 2-LTC out
- 3-ASCII in/out
- 4-NC
- 5-LTC in

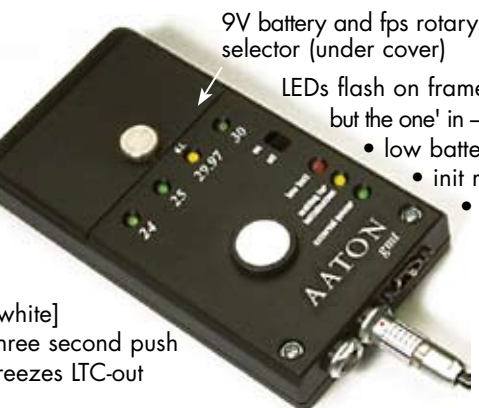
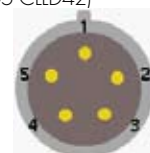

9V battery and fps rotary selector (under cover)

- LEDs flash on frame 00; 'three but the one' in -0.1% NTSC
- low battery
- init request
- ext power

[white] three second push freezes LTC-out

date generated by a brand new GMT starts at Y92/M01/D01, it is incremented by one day at each power 'ON' followed by a [white] button initialization. The "Year/Month/Day" is stored in non-volatile memory, resulting in a *never-twice-the-same date* from a given GMT.

selector: 1 = 24, 2 = 25, 3 = 29.97 DF, 4 = 30; selected fps LED flashes. 5 = 23.98NDF [24 -0.1%], 6 = 29.97NDF [30 -0.1%]; three LEDs, other than the selected fps, flash.

Connections

- Momentary initialization is done through the Lemo5 socket. GMTs delivered Lemo5 cable: Gnd blue, LTCadj. white, LTC TTL red.

- Permanent LTC generation to a video camera should preferably go through the Fischer4 which lets the camera +7/+12V be used instead of the internal 9V battery. GMT-u delivered Fischer4 cable: Gnd blue, LTCadj. white, Powerin red.

GMT, 1 ppm low-power LTC generator for SD/HD cameras.

Momentarily initialized from an ASCII master-clock or any LTC source (whatever its frame-rate), and attached to a camera, its (internally adjustable level) LTC-out is sent to the A3 audio track. This bonds the Video-TC of the camera to the free-run Audio-TC also running in Cantar and other cameras on the set. During image import, the NLE extracts this Audio-TC to «autosync» images and audio (p.46).

Emergency master-clock

Turn 'ON' GMT, press the [white] button to initialize the clock from hour 01. The

Remote roll (GMT-u only)

• Whatever the initialization mode, pressing the GMT-u [white] button for more than three seconds makes the LTC output freeze on the last TC value (the four frame-rate LEDs blink). A short push on the [white] button unfreezes the LTC. Sent by wire or radio, this signal stops and starts the Cantar recording (p.21).

Technical Specifications

- 150 gr
- 63x123x26mm
- 9V battery (150 hours working)
- 7 to 18 VDC ext. supply
- 6mA consumption
- 1 ppm clock
- LTC-out: -20 to -60dBu & TTL
- FPS

Lemo 5

- 1-Gnd
- 2-LTC in
- 3-ASCII in/out
- 4-LTC out, adj. level
- 5-LTC out, TTL level

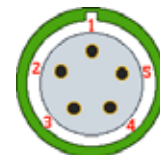

Fischer 4 (GMT-u only)

- 1-Gnd
 - 2-[White] button
 - 3-LTC-out adj.
 - 4-Power in
- (Fischer4 plug ref: S102A053130)

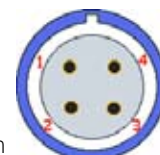

Majax

A free Aaton application devoted to the treatment of Cantar files. Works under Mac-OS and Windows XP.

<http://www.aaton.com/documentation/>



Plays ten tracks, edits metadata, converts WAV to BWF.

- Through the laptop built-in audio card, Majax plays ten tracks with $\pm 12\text{dBu}$ level and pan adjustments.
- Decodes M/S to L/R.
- Edits scene, take, take-type, track-names, DayStamp (audio reference) and recordist's comments within the Broadcast Wave metadata (iXML) fields.
- Starts 'Play' from Autoslate marks and user's tabs.
- Mixes eight monophonic tracks into two, rotates then interleaves them into polyphonic files.
- Converts any WAV file into a Cantar 'Rec&Play' compatible BWF file (see p.25).
- Corrects Cantar audio files which have been aborted by a power interruption.

Generates frame-accurate Sound-Reports

Gathering the iXML metadata generated by Cantar and edited by the operator, Majax builds a Sound-Report saved in PDF format to be mailed to the Post Production team. It also builds an ALE 'Avid Log Exchange' file which, imported before the audio files, bring the metadata (e.g. track names), that Avid MCs can't currently read in the iXML chunk.

note: to edit UDF formatted DVD-RAM discs with a Mac, install SoftArch's WriteUDF! <http://www.softarch.com> which works with OS-X 10.4 only. To get a v10.6 update, mail to support@softarch.com.

In a Mac equipped with an 'E' SuperDrive, replace it with a genuine Matsushita UJ 875, or connect a standalone DVD-RAM burner, or use the TECHSET.01 'Unmount'-ed Cantar internal DVD burner itself.

IndawPass

Tell your Post Production manager that Aaton's IndawPass is the **fastest Tape-to-Tape and Audio/Video Sync** machine in the industry when it comes to syncing audio files to DPX, HD and SD images.

<http://www.aaton.com/products/post/indaw/index.php>

Fps agnostic

IndawPass solves all the problems post-production facilities may encounter in the maze of audio-video-film speeds and standards.

Transfer-list cleaner

IndawPass also rejuvenates the ALE transfer lists sent to the Avid with better Keycode matching than the telecine originals.

The PostChain

Distribute the 'Cantar-Post-Chain' to the Post people; it will help them considerably.

<http://www.aaton.com/documentation/>

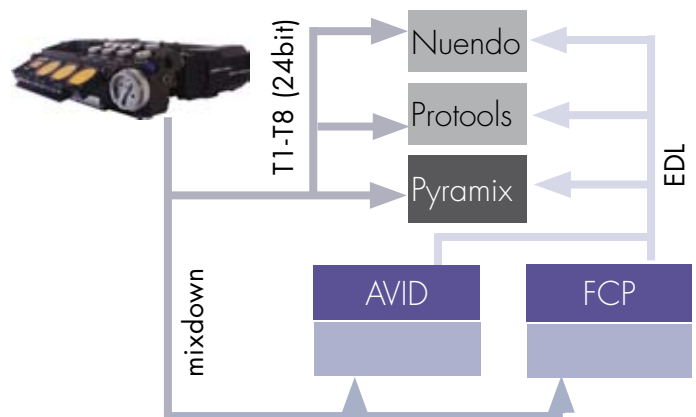

Titan-3

For autoconforming with Titan-3 **FlashConform** and **FixSync** using the Cantar filetags, get the cantar.tsc rules from Synchro Arts <http://www.synchroarts.com> or send an email to aaton-support@aaton.com.

By their very nature the Aaton filetags eliminate all TC overlaps, and this is a huge advantage over all other references!

note: Titan-3 does generate sample accurate audio confirmation lists, provided the **FixSync** process is performed immediately after the EDL driven FlashConform operations.

Connectors

Mic XLR3(F)

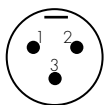

Symmetrical transformer (0dBu/+24dBu w/ pad) on mic.1, mic.2, mic.5 on XLR 3:
 1= Gnd 2= Hot 3= Cold

Mic XLR5(F)

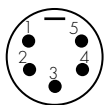

Symmetrical transformer (0dBu/+24dBu w/ pad) on mic.3 (Left or M): 1= Gnd 2= Hot 3= Cold
 mic.4 (Right or S): 1= Gnd 4= Hot 5= Cold

Line-in XLR5(F)

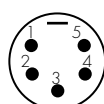

Asymmetrical (4.4k ohm, +10dBu) on line-in.1 & line-in.3: 1= Gnd 2= Hot 3= Cold
 line-in.2 & line-in.4: 1= Gnd 4= Hot 5= Cold
 The 'Cold' to 'GND' link is done at the line amplifier IC level and should not be duplicated anywhere else.

Line-out XLR5(M)

Symmetrical, -10dBu out @ -18dBFS on track (*digital camera line-in level practice is -10dBu, not 0dBu*).
 line-out.1: (stereo Left)
 1= Gnd 2= Hot 3= Cold
 line-out.2: (stereo Right)
 1= Gnd 4= Hot 5= Cold



Foldback TA-3(M) Mini-XLR3

1= Gnd 2= Left 3= Right (3.5mm Jack on earlier Cantars)

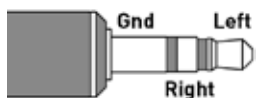

Phones 1/4" jack

8 ohm speakers up to 2Vrms



Timecode-in/out LEMO5(F)

1= Gnd 2= LTC-In 3= ASCII 4= nc 5= LTC-Out



Power XLR4(M) (max: +16.6V)

1= Gnd 2= nc 3= +Batt (Cantar#>268) 4= +Batt
 Battery internal wiring: •Aaton Li-Ion: 14.8V-out to pin-3 and through a power diode to pin-4 (protection against NiMH chargers). •Aaton NiMH 12.5V-out to pin-4.

Remote & Sync SubD 15

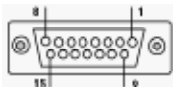

socket as seen from the outside April 2006

1	2	3	4	5	6	7	8
GND	ASCII	LTC OUT	WORDCLK	RESERVED	RESERVED	RK	TX
9	10	11	12	13	14	15	
BATTERY+	LTC IN	REC TALLY	RESERVED	RESERVED	GND	GND	

- 2 ASCII-in with motherboard CM2.6+
- 3 LTC-Gen if 'ON' in AUDIO/TC.16
- 4 Wordclock Cantar-X2 only
- 9 Batt+ Out 13±3V, polyfused @250mA
- 11 Record Tally closure to ground (p.23)

AES-in/out SubD25

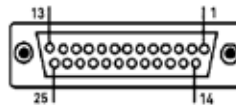

socket seen from the outside. Tascam TD88 standard

AES inputs				AES outputs			
CHANNEL PAIR	HOT +	COLD -	GND	CHANNEL PAIR	HOT +	COLD -	GND
1-2	24	12	25	1-2	18	6	19
3-4	10	23	11	3-4	4	17	5
5-6	21	9	22	5-6	15	3	16
7-8	7	20	8	7-8	1	14	2

Accessories

Line-out Booster +12

Two 12dB gain transformers make the line-out deliver 0dBu at -18dBFS track level (ref. 20-270-50).

Line-out Booster +12

USB-PS2 to SubD 15



USB-PS2 to SubD 15

Converter featuring a regulator (max 60mA, +5V), and an RS232 translator for PS2 keyboards w/ USB-like plug (ref. 59-681-91).

Only use a QWERTY US/English PS2 compliant keyboard such as the Cherry G84-4100 PTM EU:

http://www.cherry.de/english/products/keyboards_g84-4100.htm

The 'Virtually Indestructible Keyboard' is not recommended because of its improper tactile keys.

8to8 bridge

(for non SL1 equipped Cantar-X1)

Eight 26dBu /10k ohm transformer isolated balanced line-inputs to Cantar mic/line-inputs. See tutorials on:

<http://www.soft.aaton.com/swcantar>



Internal DVD-RAM drive

An Aaton deliverable mu-metal plate must be locite fastened on consumer DVD-RAM drives installed in pre-SN#240 Cantars not equipped with a built-in magnetic shield. To extract the drive, see p.5.

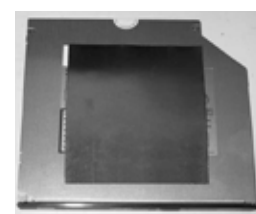

This quick guide, originally compiled by Scott J. Farr, should be kept in the Cantar bag.

0 Terminology for New Cantarites: "In", followed by STOP, TEST, PPR, REC, PLAY, BROWSE, OUT-MAPS, IN-GRIDS, AUDIO/TC, TECHSET, SESSION, or BACKUP, means to turn the [MainSelector] to that position (p.10 & p.26).

1 Power On: Press either [batt] button for 3 seconds. To switch batteries, press a [batt] button for 3 seconds. To activate both batteries, press both [batt] buttons for 3 seconds.

2 Power Off: In STOP, press the [shift] + [batt] buttons for 3 seconds.

3 Check Battery Anytime: Momentarily press the [batt] button for the battery you want to check.

4 Clear flashing 'intc': Press [shift] + [TC jam] (p.13).

5 Jam to External TC: Press [TC jam] (p.14).

6 False Start Take Erasure: Don't rotate the [MainSelector] past PPR; while in PPR press [shift] + [silver] then [jog] to 'Erase file'. Press [ok] then [jog] to 'Yes', and press [ok] (p.20).

7 No Good Take: While recording, repeatedly press the [gold] button until 'n' (No Good) is displayed. This file is stored in the trashcan. The next take will have the same scene and take # (p.22).

8 Revive Trashed Files: In BROWSE, [jog] to select 'TRASH'. [jog] to select the filetag (p.25).

9 Erase comment line: Press [shift] + [esc] (p.6).

10 Choosing Take Type: T = Sync'd Take, P = Pickup, W = Wild, A = Announce, N = No Good. The choice can be made with the [gold] button while in PPR or REC (p.19).

11 Arm/Disarm a Track: In TEST, pull [SoloMixPan] to the operator. Press [shift] + a [track-solo] button above the track fader you want to Arm/Disarm (p.18).

12 AutoSlate: Press [shift] + [silver] within six seconds after each slate clap. The slates generated by a multi-camera shoot are labeled SA, SB, SC, etc. (up to 7) (p.23).

13 Tone: In TEST, PPR or REC, press [shift] + [gold] and release [shift] first. To cancel, press [shift] (p.22).

14 View 'Record Time' or 'Scene Info': while in REC, press [shift] + [eye] to toggle rectangular screen bottom row (p.8).

15 Slate Mic: In TEST, PPR or REC, press [black] for left channel, double press [black] for right channel, or press [shift] + [black] for all armed tracks and outputs (p.22).

16 Adjusting Line-out Level: In TEST, press [shift] + [silver] to access the 'LVL&DELAY' menu. [ok] to access current value. [jog] to change. [ok] to accept new value. You can activate Tone or use the Talkback Mic while making adjustments (p.18).

17 Adjusting Foldback Level: In TEST, press [shift] + [silver] to access the 'LVL&DELAY' menu. [jog] to 'Foldback Lvl'. [ok] to access current value. [jog] to change. [ok] to accept new value. You can activate Tone or use the Talkback Mic while making adjustments (p.18).

18 Lock/Unlock the Faders: For 5 seconds, press each [link-lock] button between the Mic-1 and Mic-2 faders and the Mic-3 and Mic-4 faders. Watch the rectangular screen. This will reset upon power down or rotating the [MainSelector] past the #6 position (p.22).

19 Pre-Record Metadata entry: In PPR, [jog] to each metadata item. [ok] to enter. [ok] when done to accept new data. [shift] + [jog] accelerates letter scrolling x10 (p.19).

20 Post-Record Metadata entry: Don't rotate the [MainSelector] past PPR; while in PPR press [shift] + [silver] to get to 'PREV' or 'EDIT'. [jog] to each metadata item. [ok] to enter. [ok] when done to accept new data. [shift] + [jog] accelerates letter scrolling x10 (p.20).

21 Playback Last Take: In PLAY, using [jog], you can fast forward and rewind through the take. [shift] + [silver] starts the playback at the slate marks. [shift] + [jog] accelerates speed x10 (p.24). (More commands on p.58)

22 Formatting DVD-RAM (UDF1.5): In SESSION (2 o'clock), [jog] to '04 Disk Format'. [jog] to 'Yes'. Hold [shift] + [gold] and insert the DVD-RAM disc. When 'Formatting' is displayed, release the two buttons. This operation may take 60 seconds (p.37).

23 Formatting HDD/SSD (FAT32): In SESSION (2 o'clock), [jog] to '04 Disk Format'. [jog] to 'Yes'. Hold [shift] + [gold] and connect the FireWire cable into the HDD. When 'Formatting' is displayed, release buttons. This operation may take 60 seconds (p.36).

24 Tracks 7/8: In IN-GRIDS (5 o'clock), press [ok] to access routings. [jog] to select, [ok] to accept (p.28).

25 Sound Report on Int HDD: Before copying files from the Internal HDD, go to BACKUP (1 o'clock). [jog] to '11 Snap Report'. Press [ok] (p.41).

26 Sound Report on Ext Device: Before ejecting the DVD-RAM or disconnecting the Ext HDD, go to BACKUP (1 o'clock). [jog] to '12 IdleSndRpt'. Press [ok]. Select 'Yes'. then [ok] (p.41).

27 Right Modulometer Source: In TEST, PPR or REC, the [eye] button toggles between tracks 5/6 or tracks 7/8 for display (p.8).

28 Change Rectangular Screen Top Line: In TEST or REC, use the [jog] to select: battery levels, available recording time, remaining storage space or mixdown modulometers (p.8).

29 Input Grids: In TEST or PPR, push the [SoloMixPan] slider toward the battery. Press [routing] then rotate the silver [config] crown (p.9) to select a preset. Press [routing] to retain the choice (p.18).

30 Output Maps: In TEST or PPR, pull the [SoloMixPan] slider toward the operator. Press [routing] then rotate the black [monitor] crown (p.9) to select which output to view. Rotate the silver [config] crown to select a preset. Press [routing] to retain the choice (p.18).

31 Setup Files: Save a configuration setup, on the HDD, for each of your regular workflows (e.g. video, film, EFX, etc.). Go in and out 'REC' right after the setup saving to attach an auto-label to the file; you will re-label it when the HDD is mounted to your Mac or PC. Setup files can be emailed and used in any Cantar (p.33).

32 Tarkan: Turn off Bluetooth, WiFi and Firewall, quit Skype and Widgets on your PC (XP, Vista) or Mac (OSX 10.4+). In PPR, connect CAT-5 (RJ-45) cable and wait for up to 60 seconds on PC or 10 seconds on Mac before clicking the Tarkan 'connect' button (p.51).

33 Help: Press the [eye] button while in any menu for a description of its features.

34 Playback Commands: (p.24)

[ok]: start/stop & send to cue-in.

[shift] + [ok]: display digitization parameters and TC fps.

[<] or [>]: go to prev/next play-card (or file, if no card).

[shift] + [<] or [>]: go to prev/next play-file.

[esc]: pause/resume.

[shift] + [esc]: continuous file-to-file play (not in BLUE-PLAY).

[black]: cue-in (volatile in PLAY).

[shift] + [black]: send player to start of take.

[gold]: cue-out in BLUE-PLAY; erases cues [jog]-ed to 00:00.

[shift] + [gold]: hide play-card from Rec&Play list.

[silver]: send player to user-entered markers.

[shift] + [silver]: send player to AutoSlate markers.

[jog]: scrub audio.

[shift] + [jog]: accelerate scrub x10.

[shift] + [eye]: toggle filetags&duration vs. scene&take (pref. stored until Cantar is turned 'OFF'). N/A in BLUE-PLAY.

[TC jam]: display player's relative-TC or absolute-TC.